

# Reductionism

# Reductionism

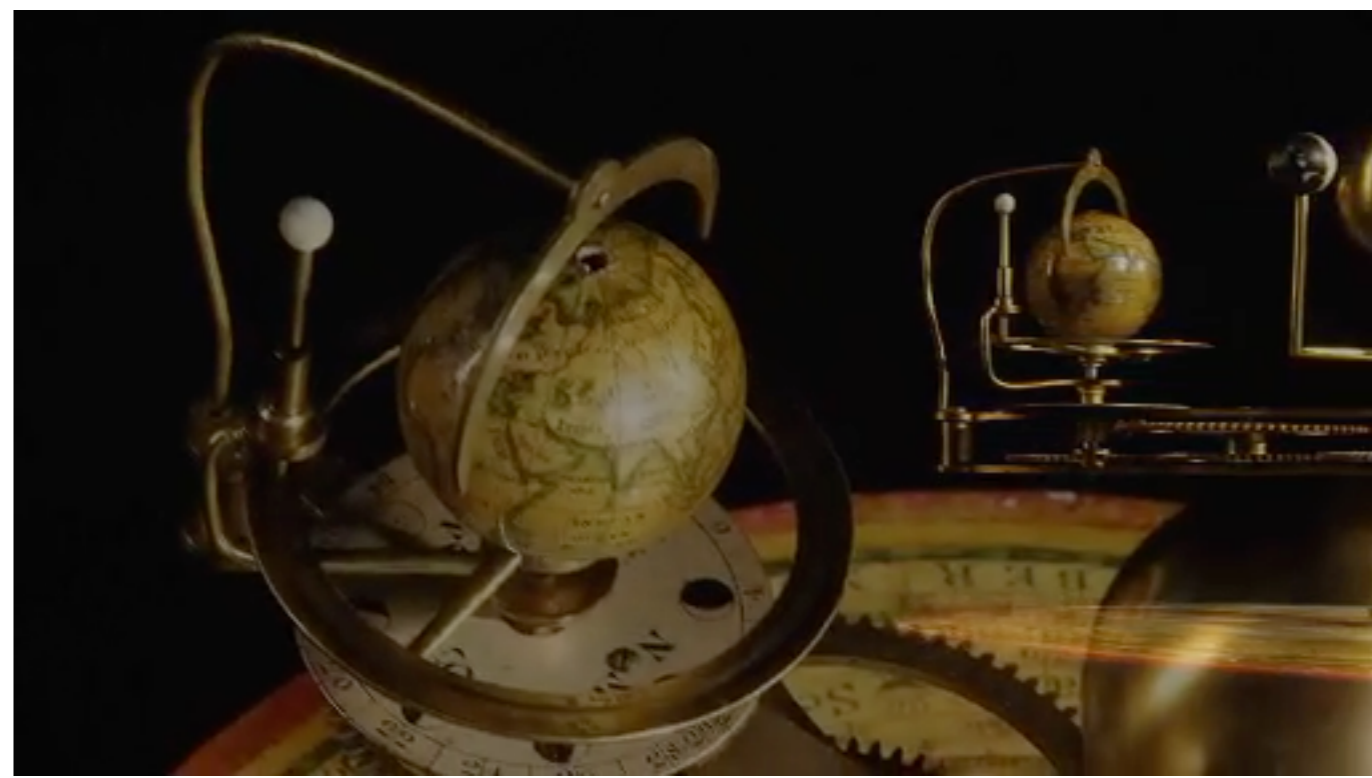

# Reductionism



Reductionism is the marvelous idea that as we take matter apart to its smallest constituents and understand the laws and forces that govern them, we can understand everything.

# Reductionism



Reductionism is the marvelous idea that as we take matter apart to its smallest constituents and understand the laws and forces that govern them, we can understand everything.

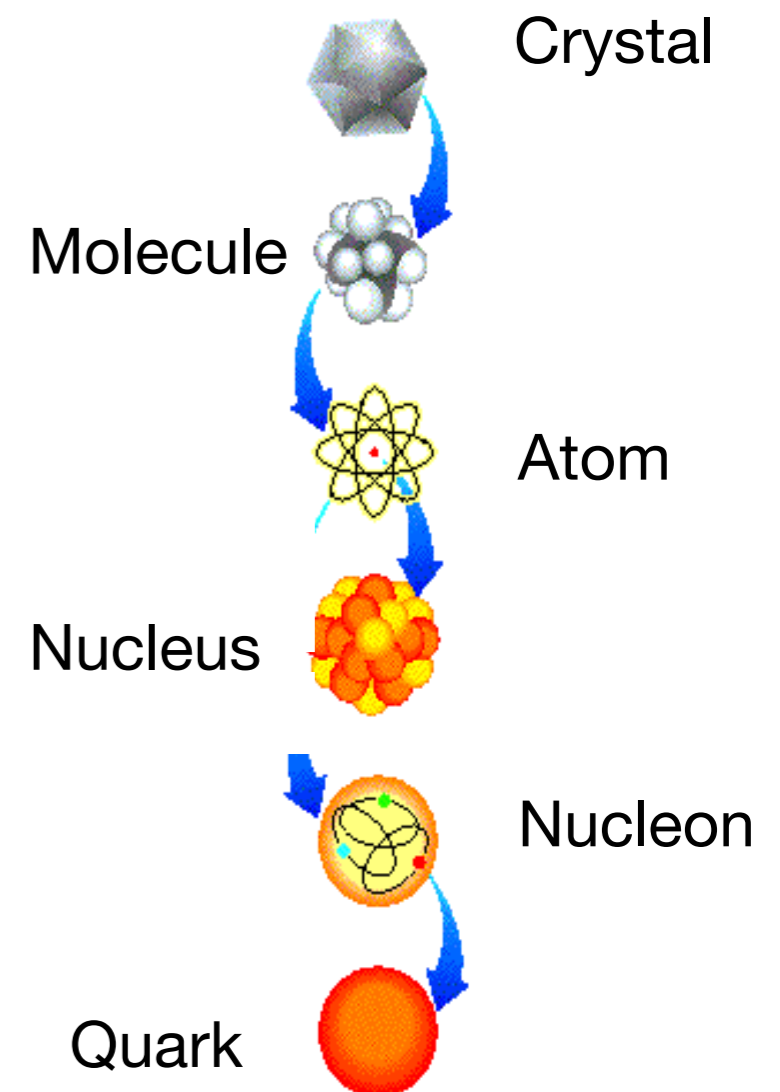

# Reductionism

20th Century. Atoms, particles, relativity, Quantum mechanics, Prediction of Antimatter, Discovery of gauge symmetries: **a monumental tribute to the power of reductionism** (Pais).

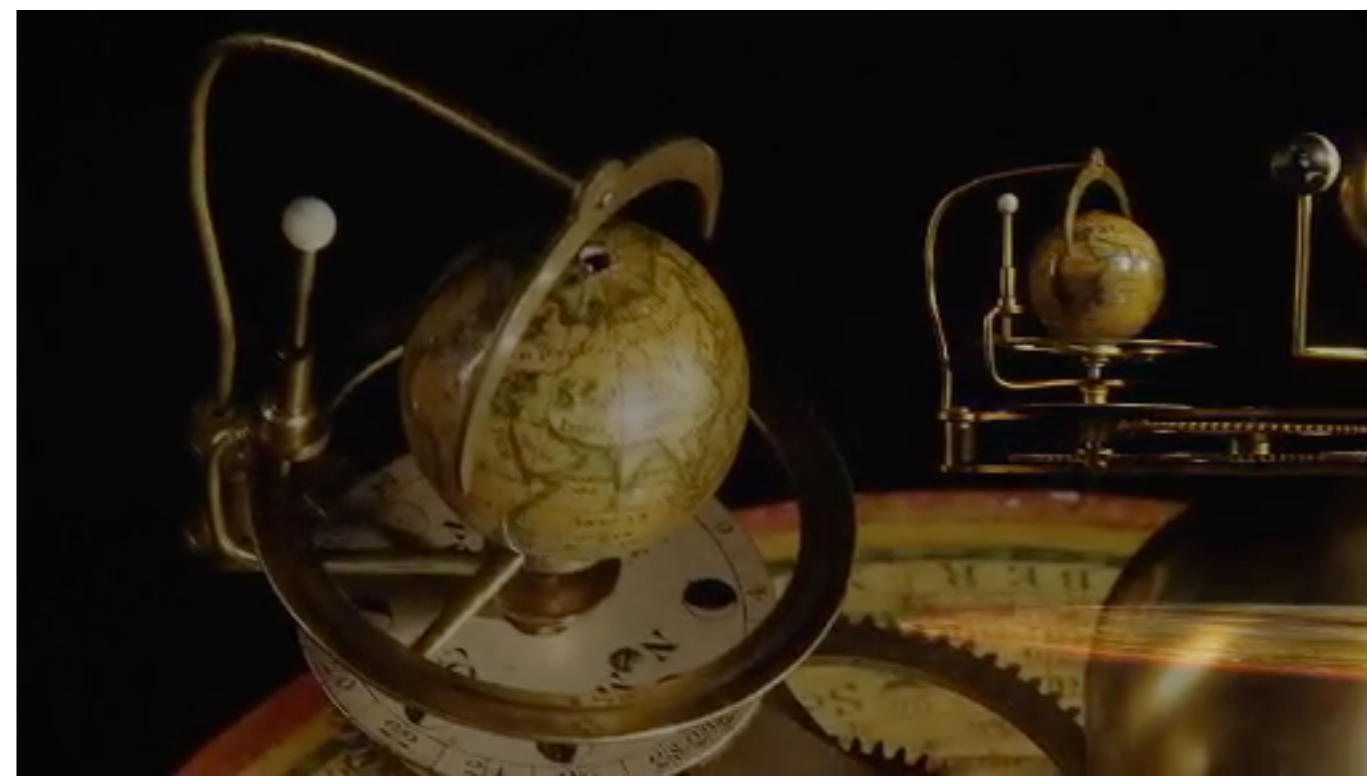

Reductionism is the marvelous idea that as we take matter apart to its smallest constituents and understand the laws and forces that govern them, we can understand everything.

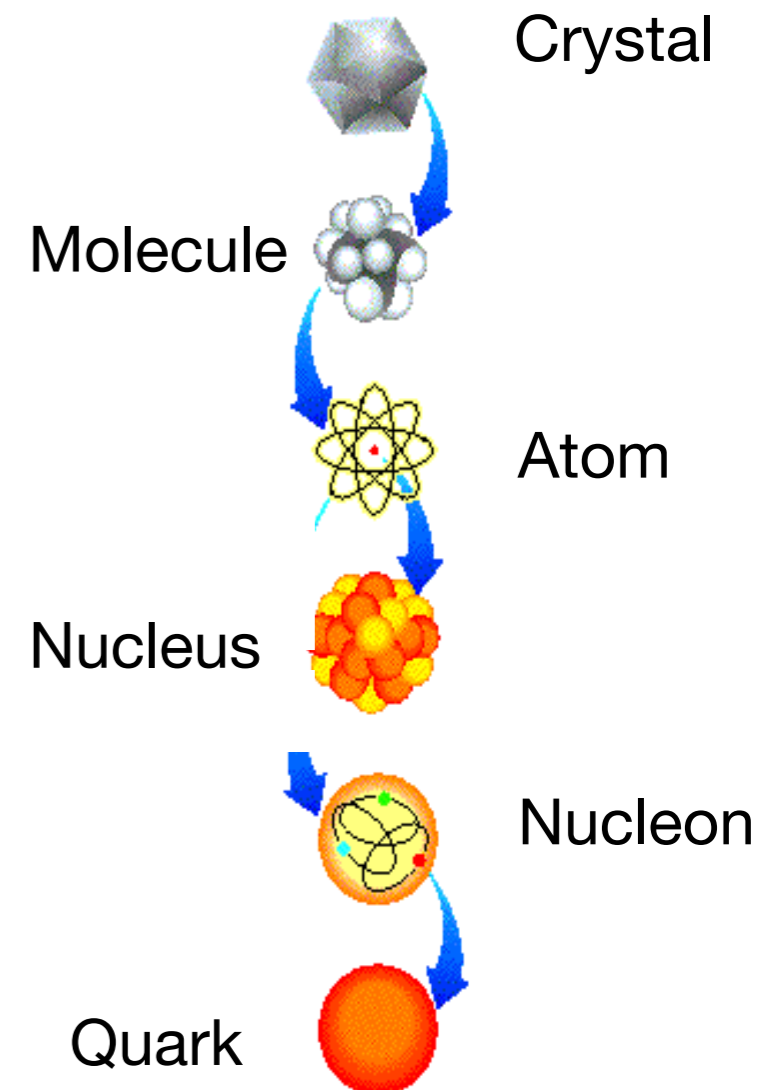

# Reductionism

20th Century. Atoms, particles, relativity, Quantum mechanics, Prediction of Antimatter, Discovery of gauge symmetries: **a monumental tribute to the power of reductionism** (Pais).

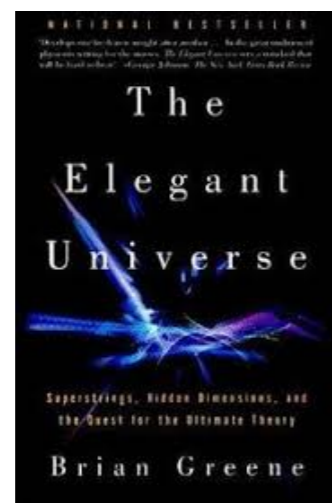
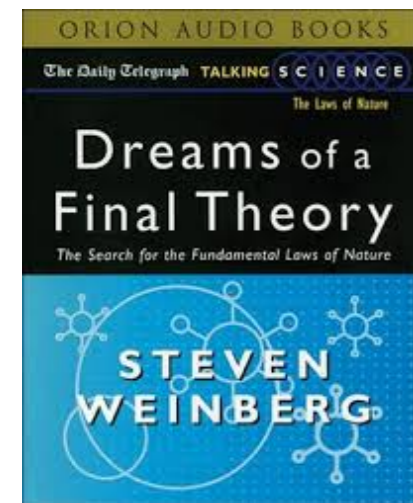
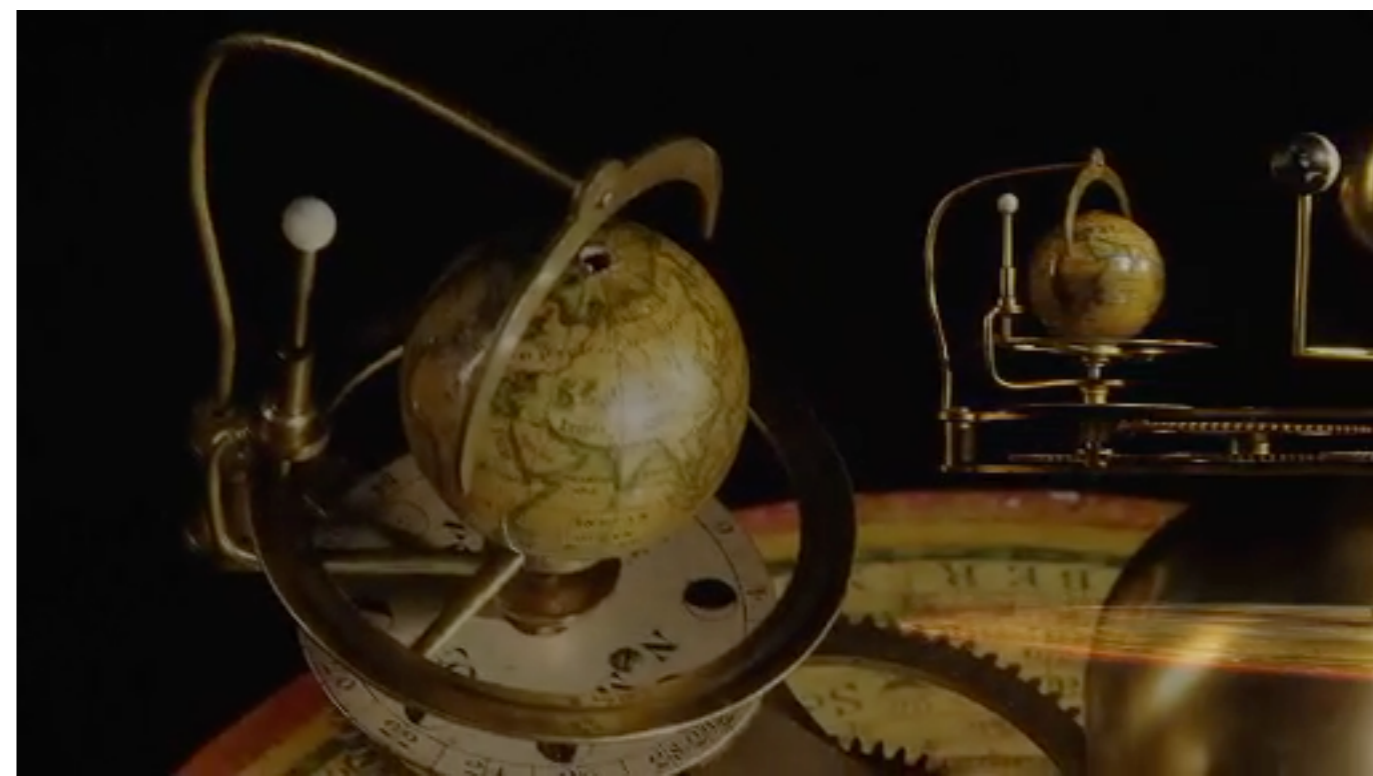

These expositions capture the beauty and romance of discovery , yet they also give rise to an impression that the frontier of science is purely reductionist, and that the frontiers lie exclusively at the extremes of scale

# Reductionism

20th Century. Atoms, particles, relativity, Quantum mechanics, Prediction of Antimatter, Discovery of gauge symmetries: **a monumental tribute to the power of reductionism** (Pais).

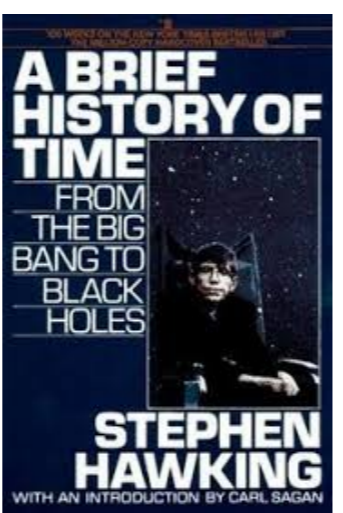
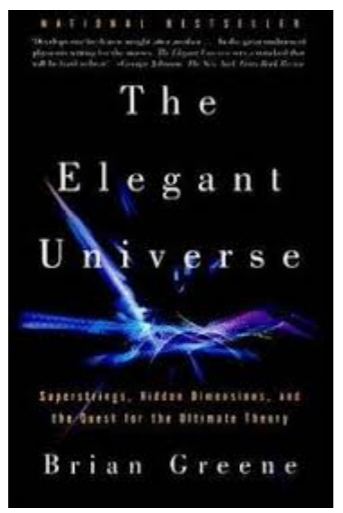
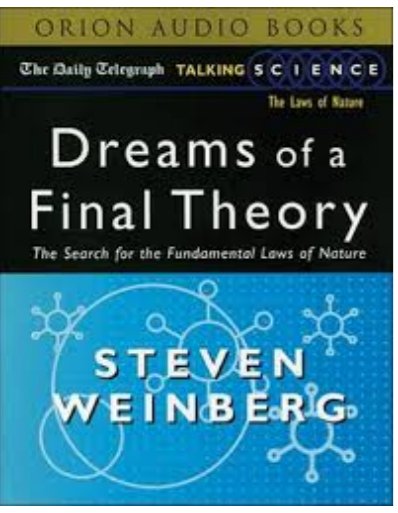
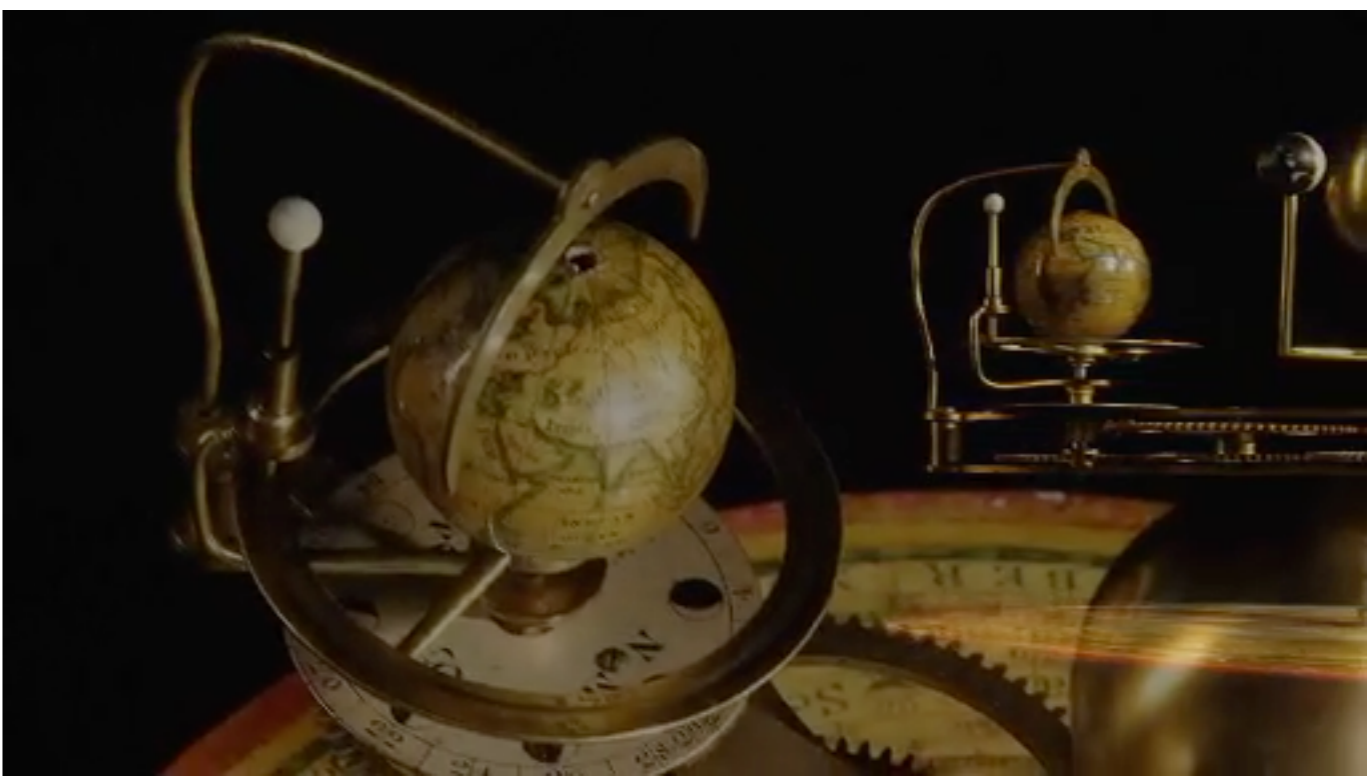

These expositions capture the beauty and romance of discovery, yet they also give rise to an impression that the frontier of science is purely reductionist, and that the frontiers lie exclusively at the extremes of scale

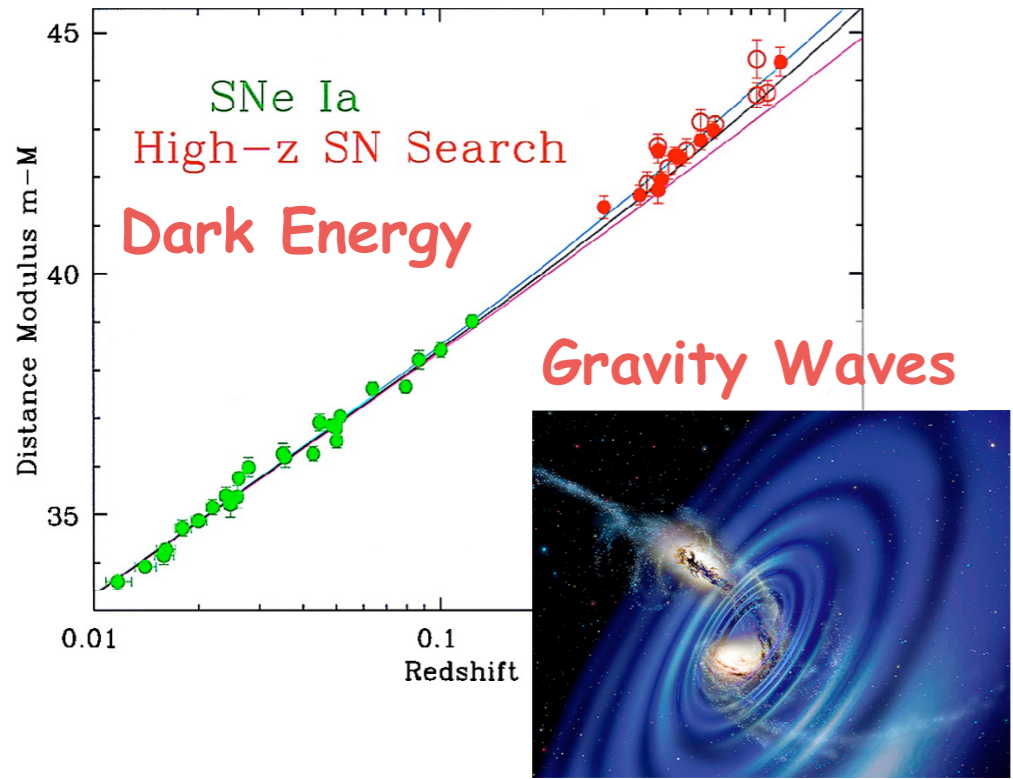

# Reductionism

20th Century. Atoms, particles, relativity, Quantum mechanics, Prediction of Antimatter, Discovery of gauge symmetries: **a monumental tribute to the power of reductionism** (Pais).

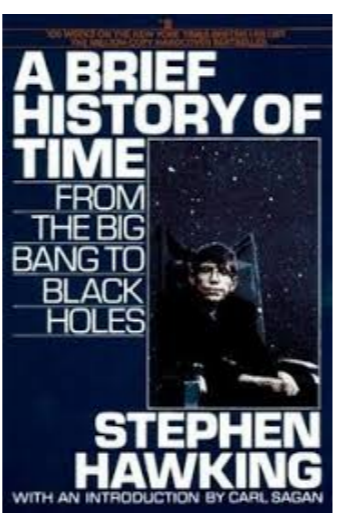
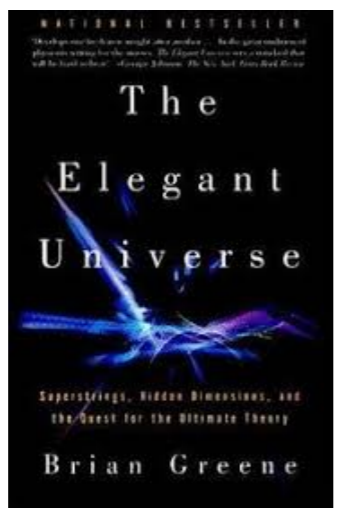
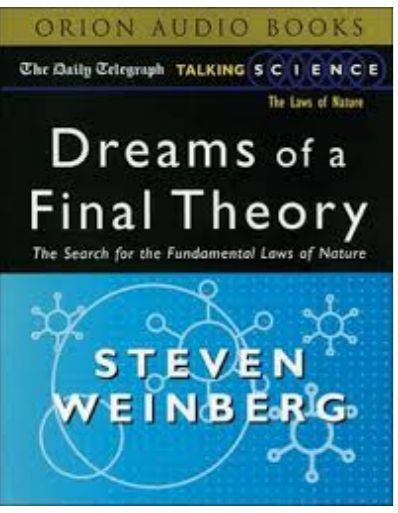
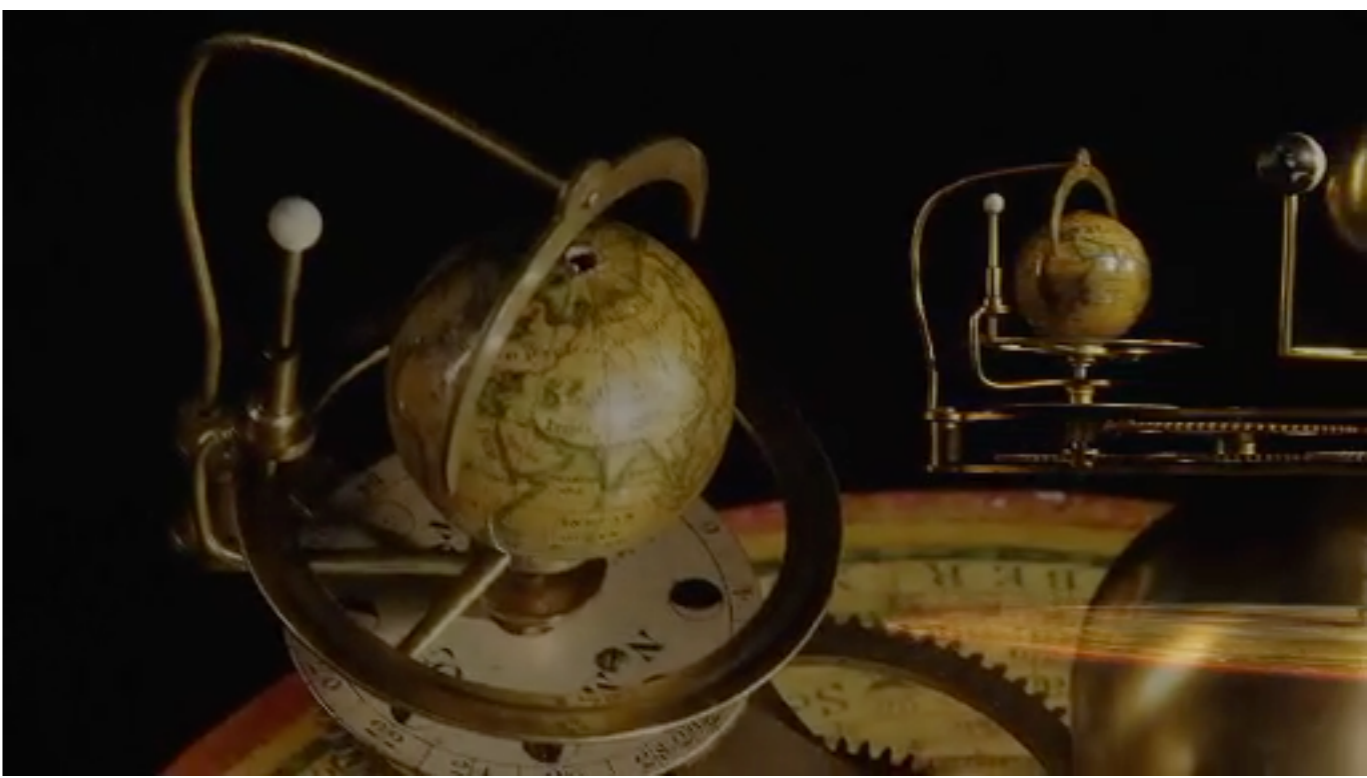

These expositions capture the beauty and romance of discovery, yet they also give rise to an impression that the frontier of science is purely reductionist, and that the frontiers lie exclusively at the extremes of scale

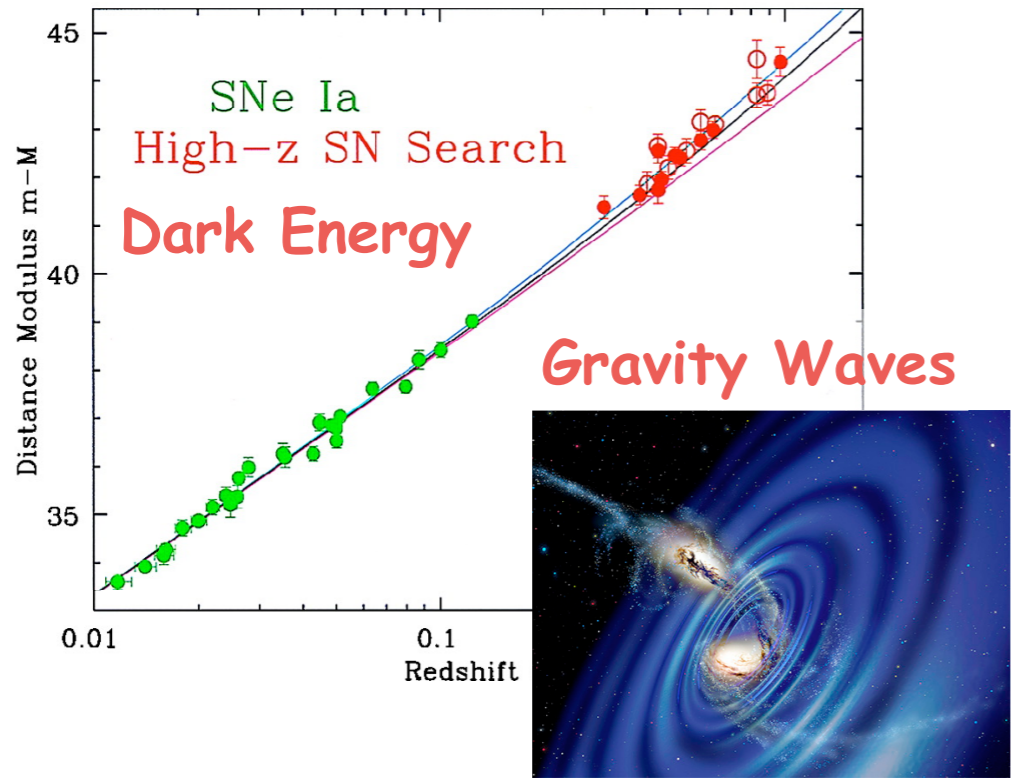

Higgs

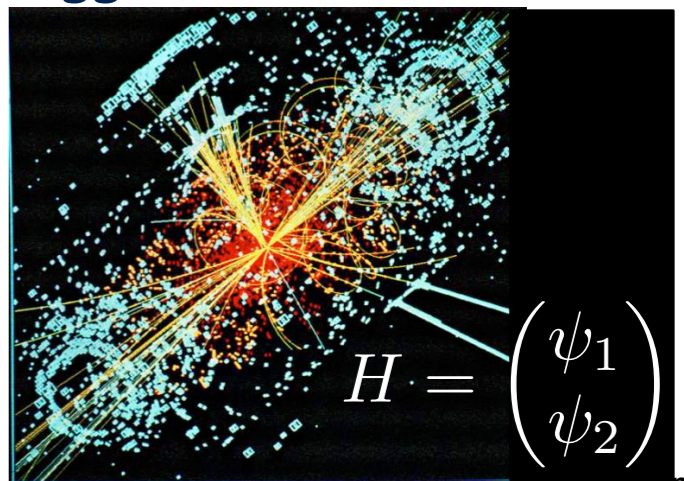



# Reductionism

20th Century. Atoms, particles, relativity, Quantum mechanics, Prediction of Antimatter, Discovery of gauge symmetries: **a monumental tribute to the power of reductionism** (Pais).

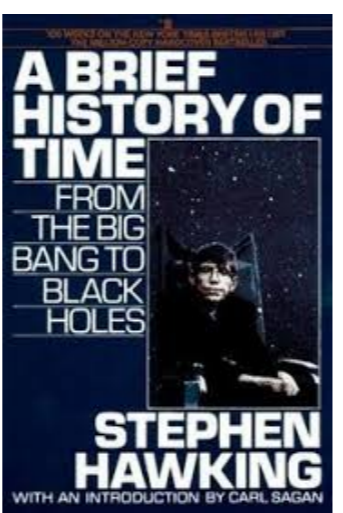
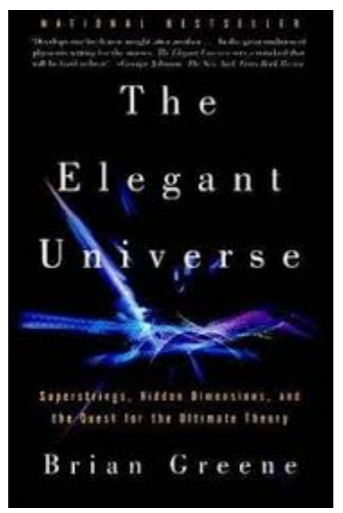
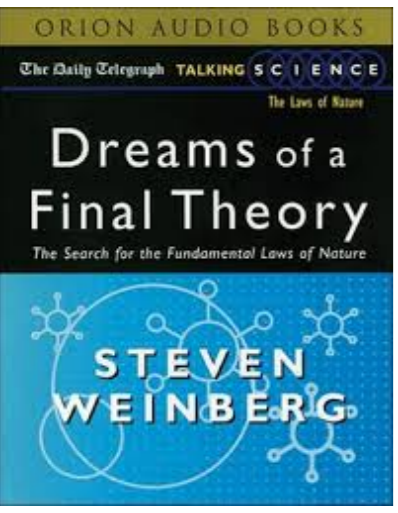
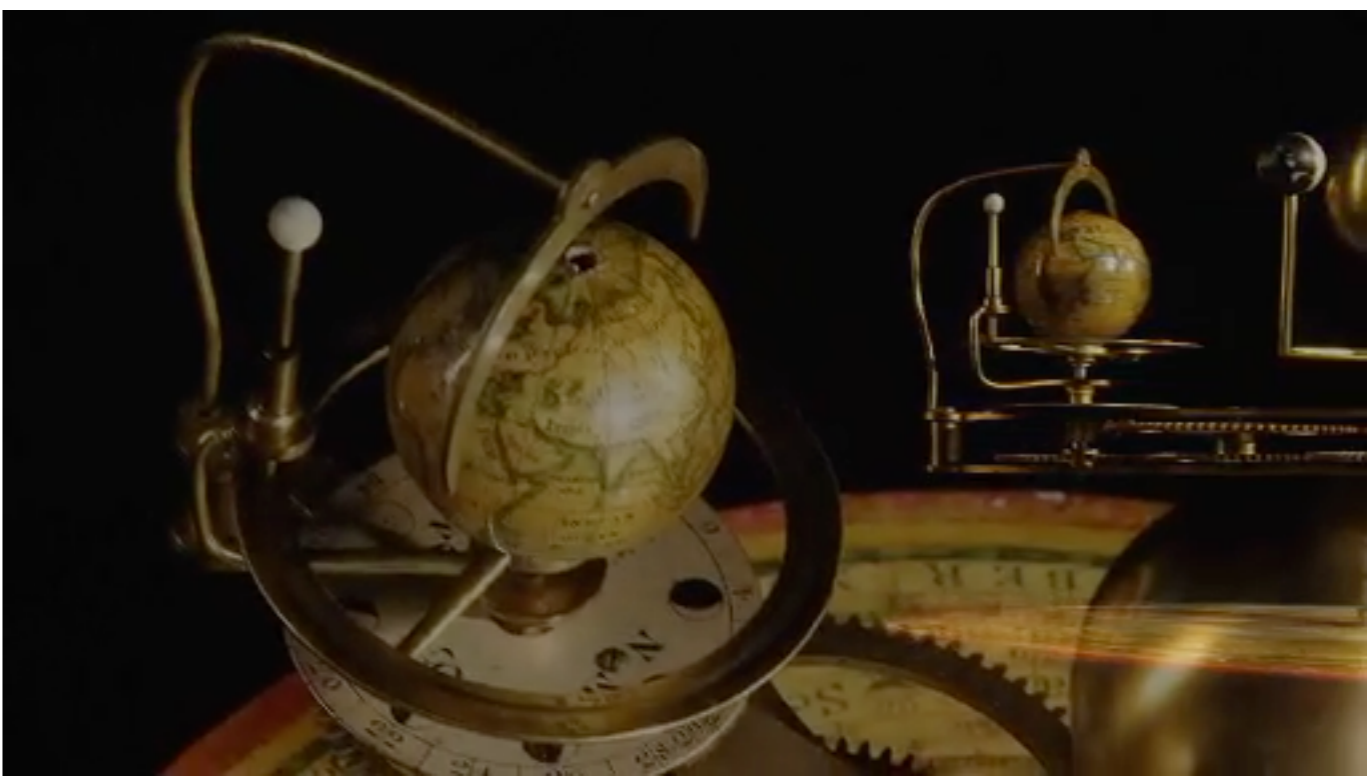

These expositions capture the beauty and romance of discovery, yet they also give rise to an impression that the frontier of science is purely reductionist, and that the frontiers lie exclusively at the extremes of scale

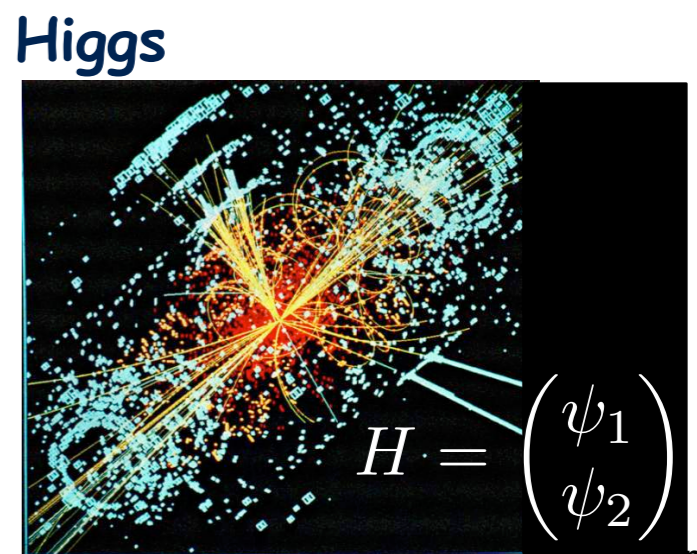
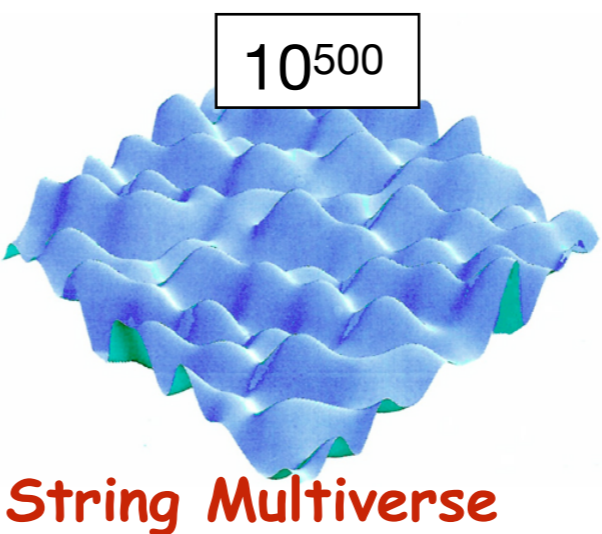
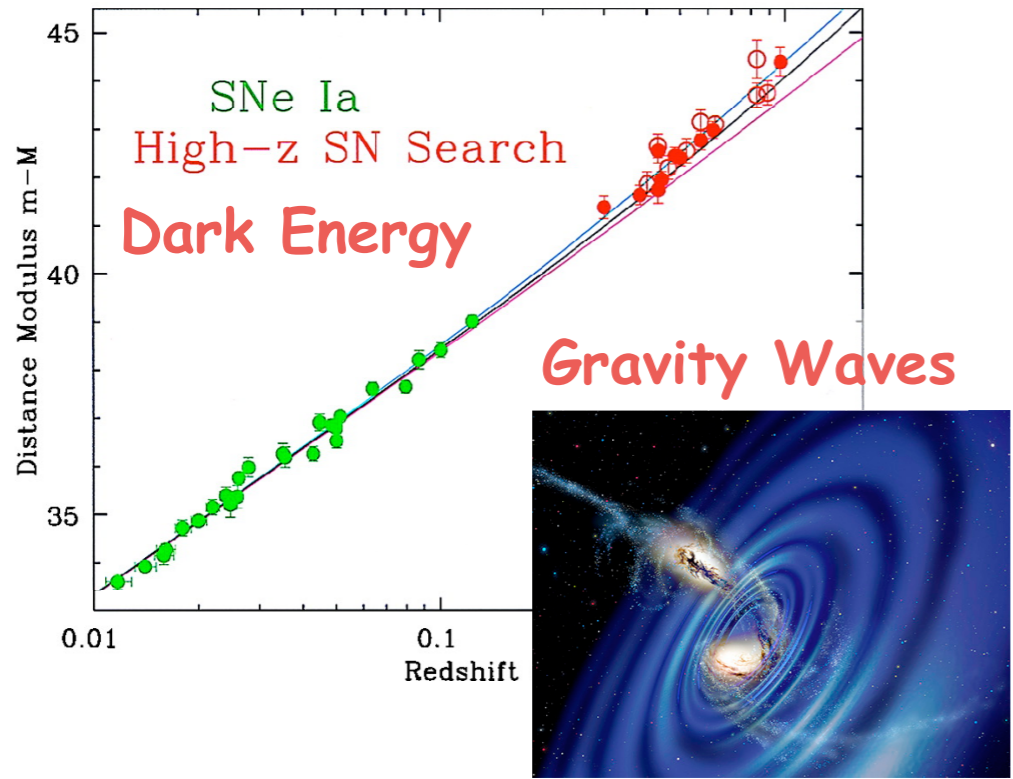

# Reductionism and Emergence

Emergence, by contrast, is the intriguing idea that as matter comes together, it develops novel properties and unexpected patterns of collective behavior.

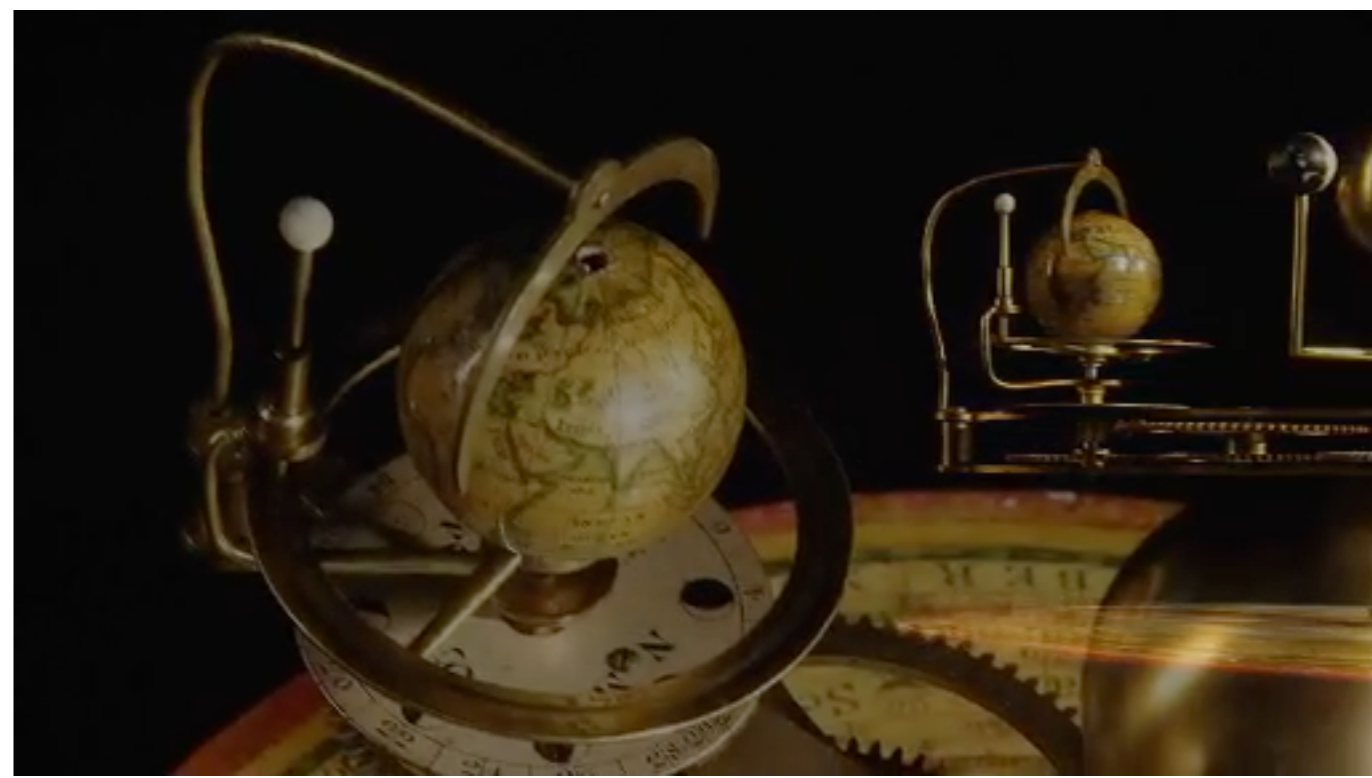

# Reductionism and Emergence

Emergence, by contrast, is the intriguing idea that as matter comes together, it develops novel properties and unexpected patterns of collective behavior.



# Reductionism and Emergence

Emergence, by contrast, is the intriguing idea that as matter comes together, it develops novel properties and unexpected patterns of collective behavior.

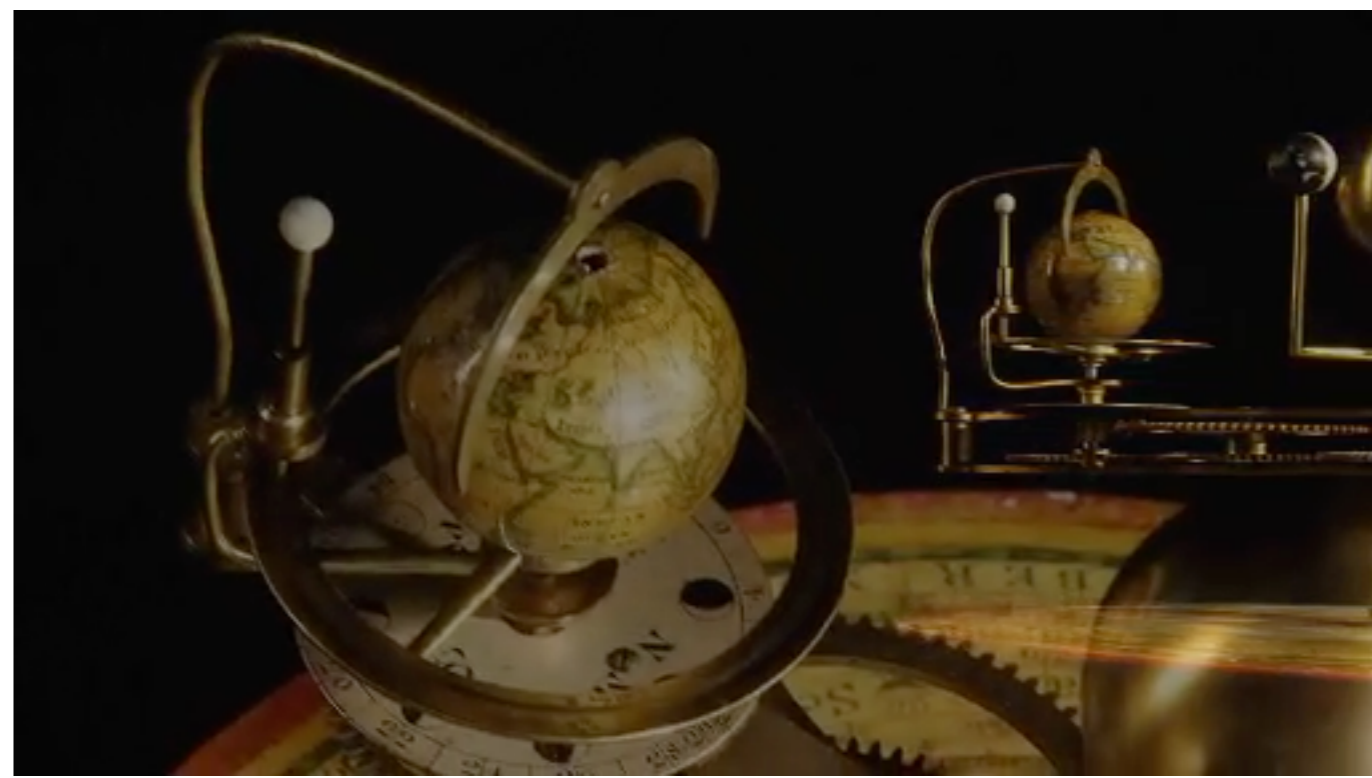

# Reductionism and Emergence

Emergence, by contrast, is the intriguing idea that as matter comes together, it develops novel properties and unexpected patterns of collective behavior.

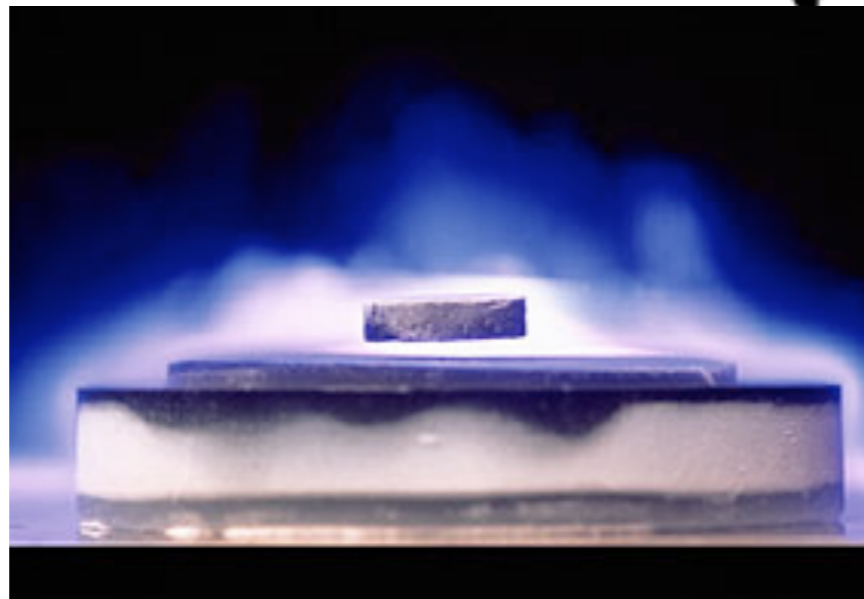
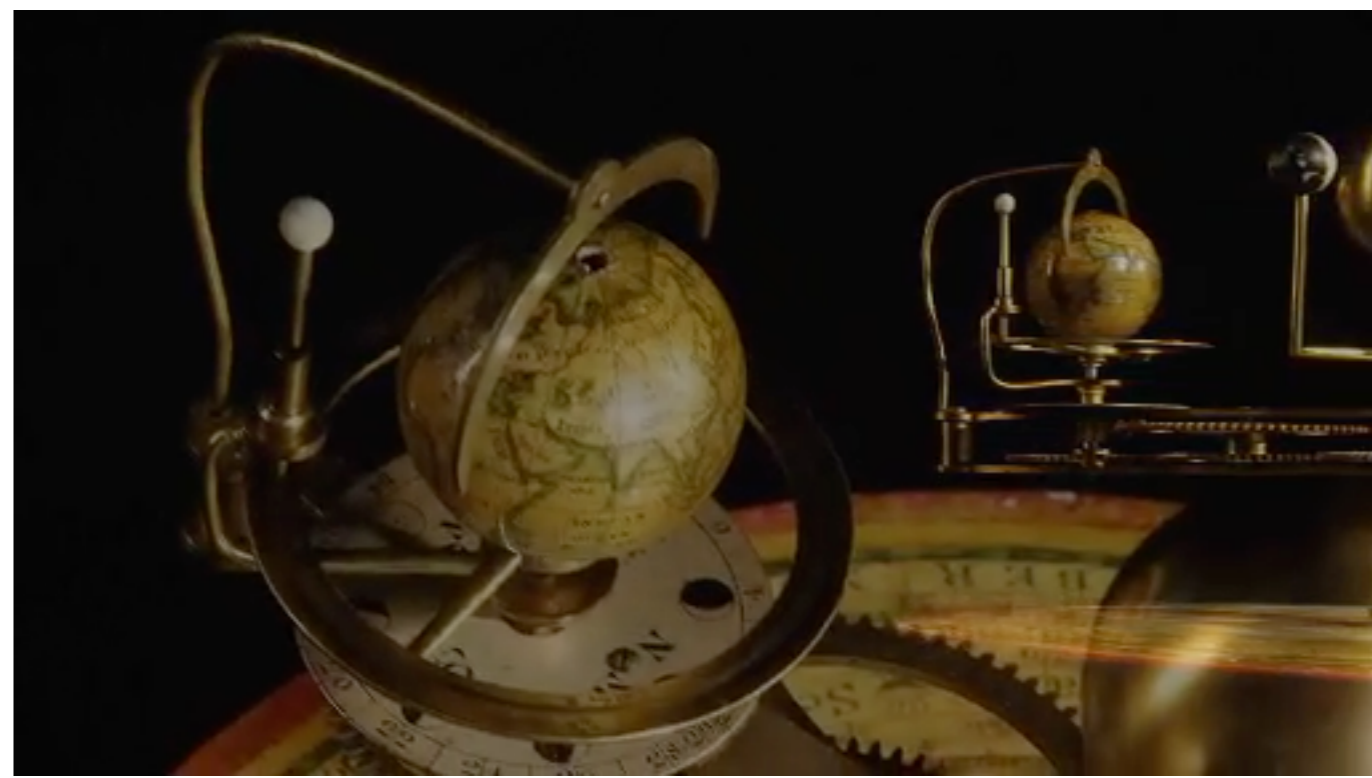

# Reductionism and Emergence

Emergence, by contrast, is the intriguing idea that as matter comes together, it develops novel properties and unexpected patterns of collective behavior.

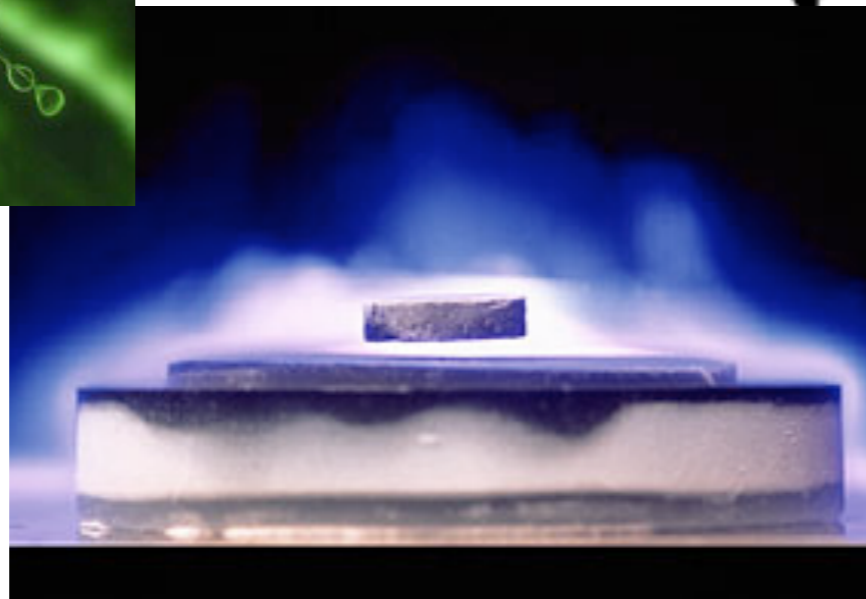
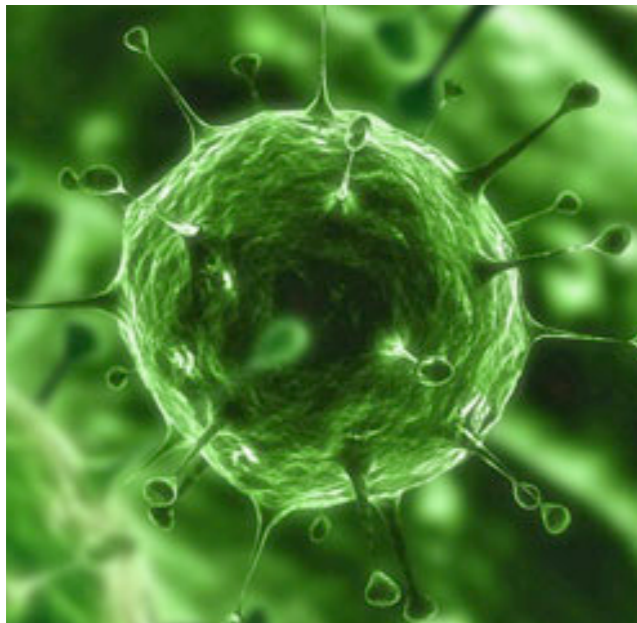
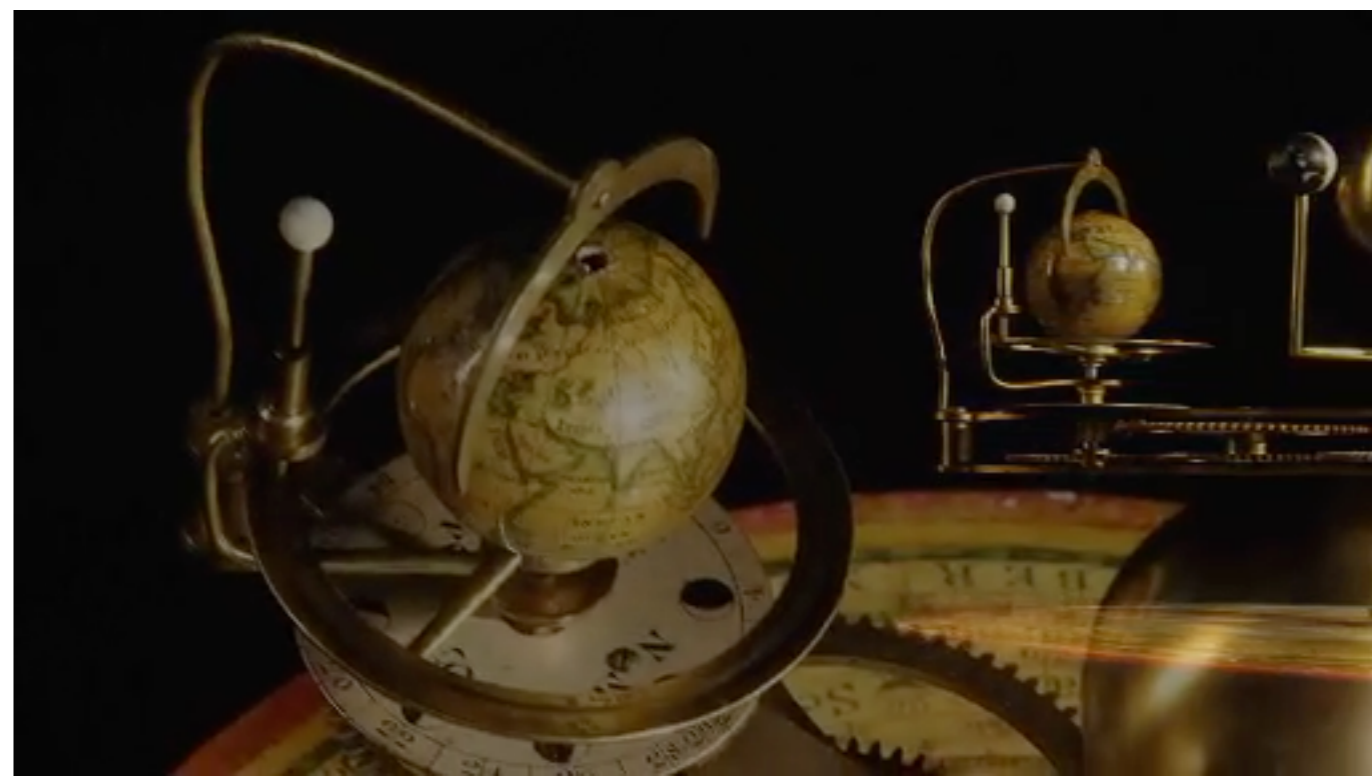

# More is Different

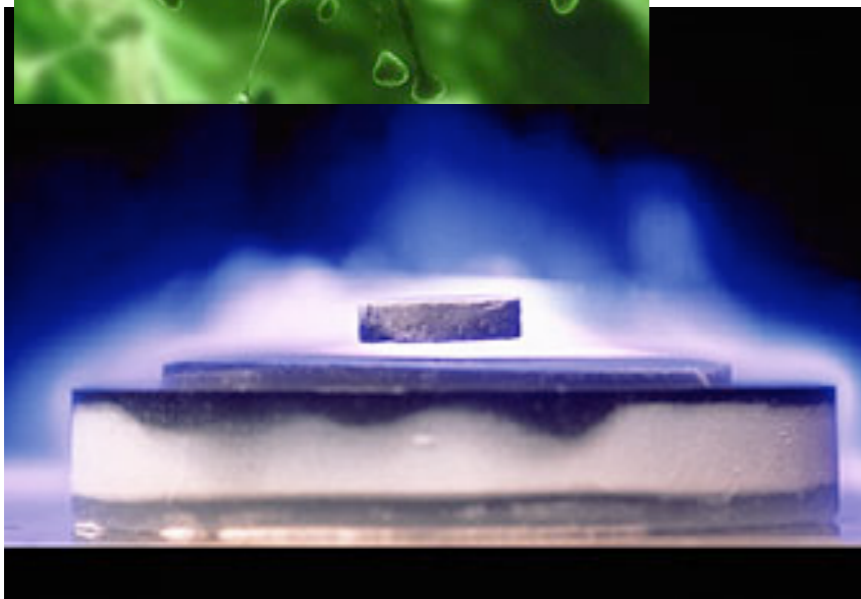
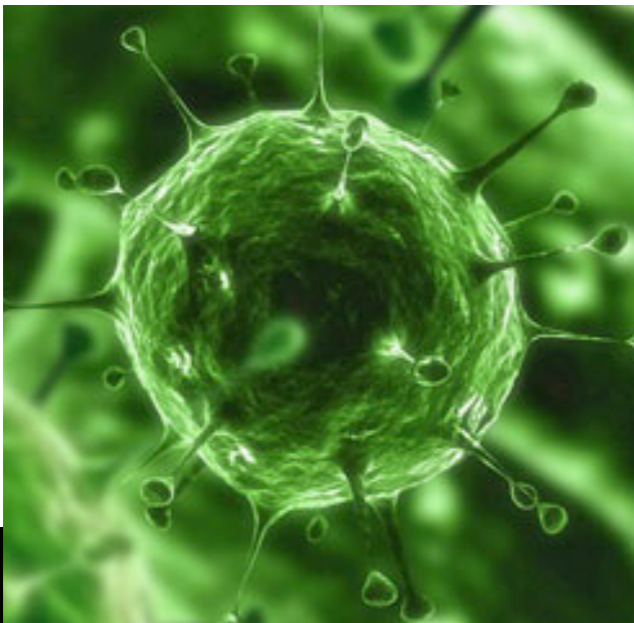

# More is Different



*“The behavior of large and complex aggregations of elementary particles, it turns out, is not to be understood in terms of a simple extrapolation of the properties of a few particles. Instead, at each level of complexity entirely new properties appear, and the understanding of the new behaviors requires research which I think is as fundamental in its nature as any other.” Philip. W. Anderson “More is Different”, 1967.*

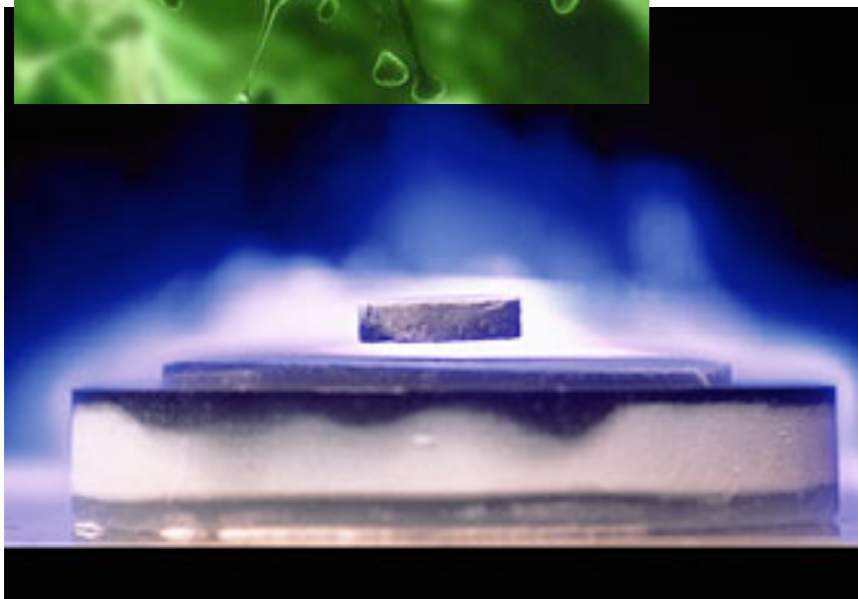
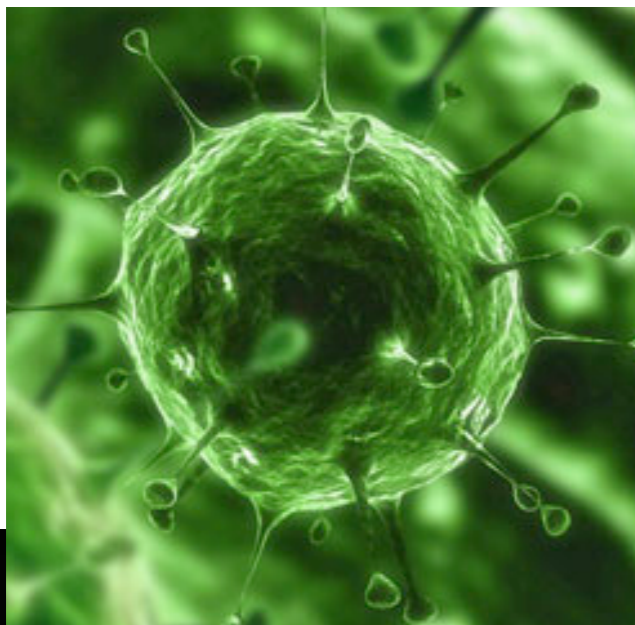



# More is Different



*“The behavior of large and complex aggregations of elementary particles, it turns out, is not to be understood in terms of a simple extrapolation of the properties of a few particles. Instead, at each level of complexity entirely new properties appear, and the understanding of the new behaviors requires research which I think is as fundamental in its nature as any other.” Philip. W. Anderson “More is Different”, 1967.*

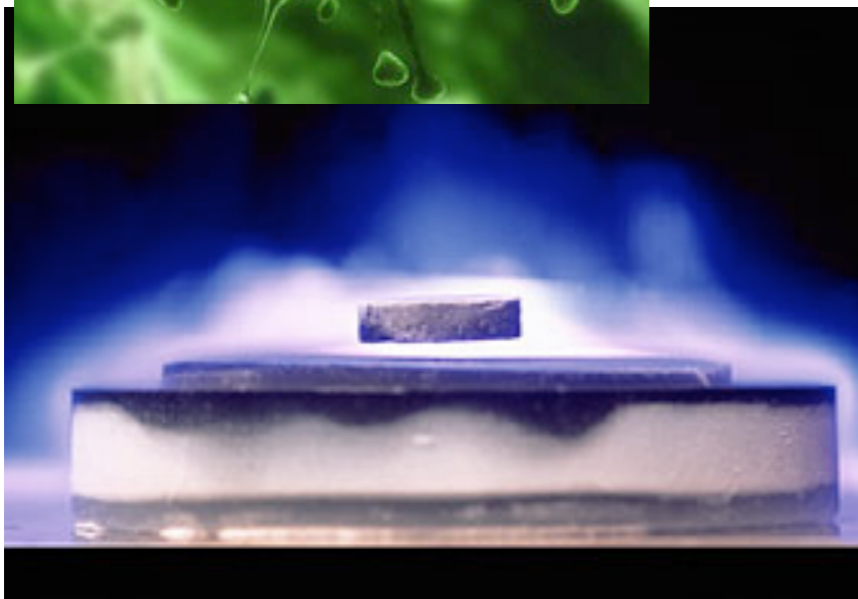
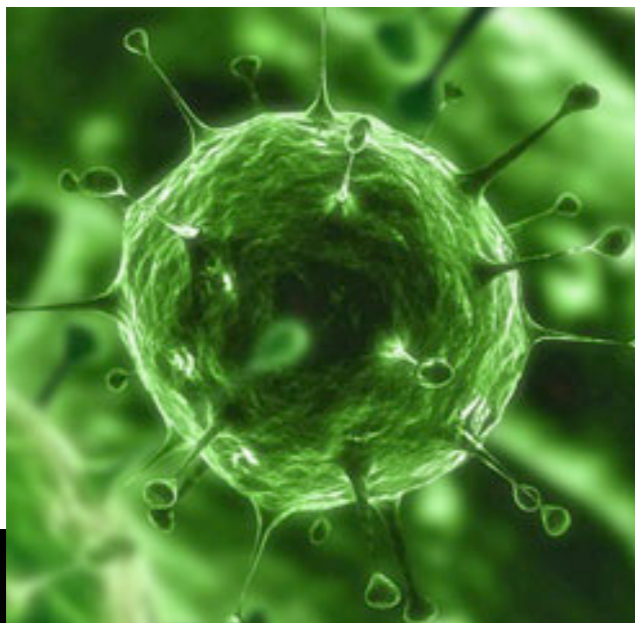

Higgs



$$H = \begin{pmatrix} \psi_1 \\ \psi_2 \end{pmatrix}$$

# More is Different

Quantum Phase Transition

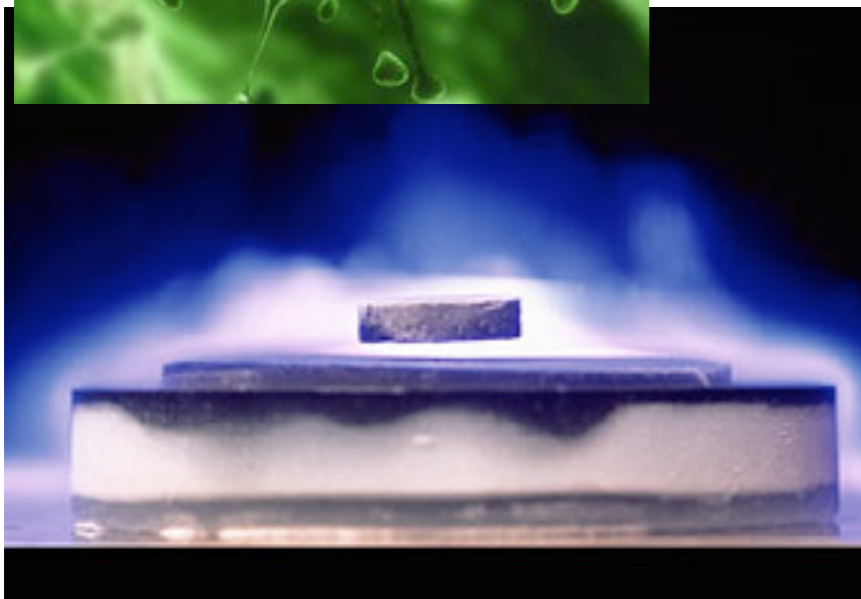
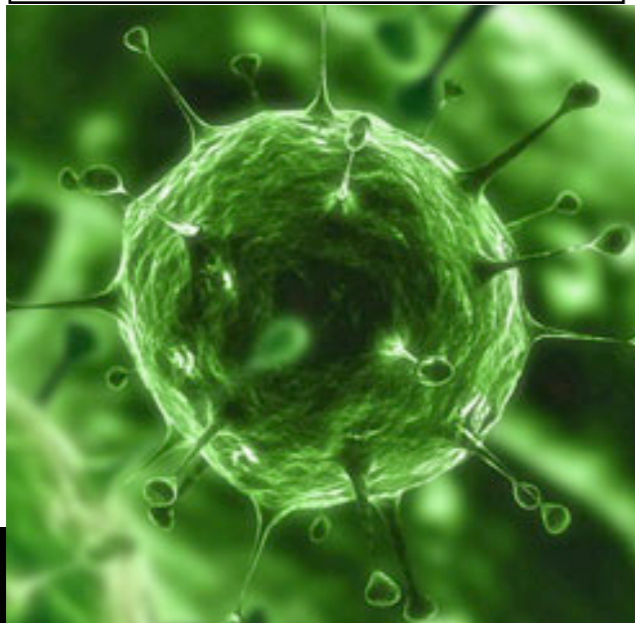
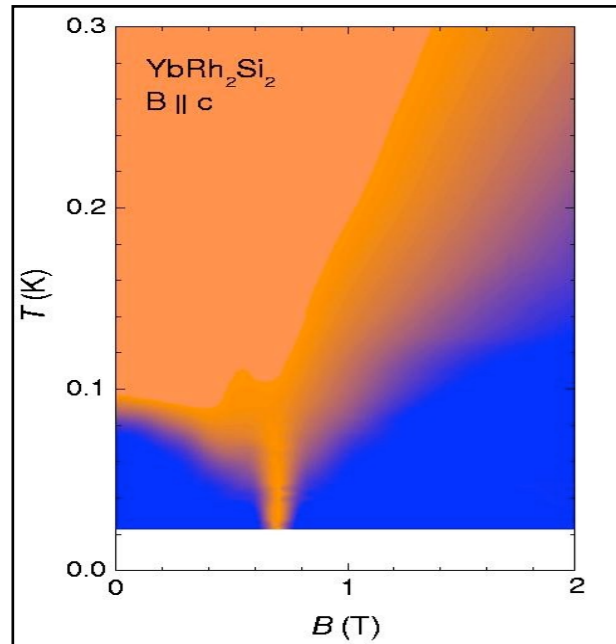

*“The behavior of large and complex aggregations of elementary particles, it turns out, is not to be understood in terms of a simple extrapolation of the properties of a few particles. Instead, at each level of complexity entirely new properties appear, and the understanding of the new behaviors requires research which I think is as fundamental in its nature as any other.” Philip. W. Anderson “More is Different”, 1967.*



Higgs



# More is Different

Quantum Phase

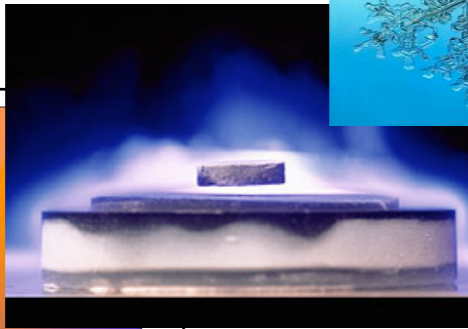
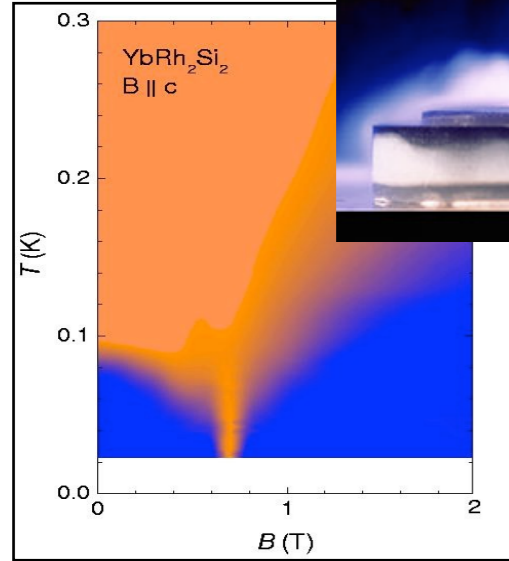

*“The behavior of large and complex aggregations of elementary particles, it turns out, is not to be understood in terms of a simple extrapolation of the properties of a few particles. Instead, at each level of complexity entirely new properties appear, and the understanding of the new behaviors requires research which I think is as fundamental in its nature as any other.” Philip. W. Anderson “More is Different”, 1967.*

# More is Different

Å | | | | μm

Quantum Phase

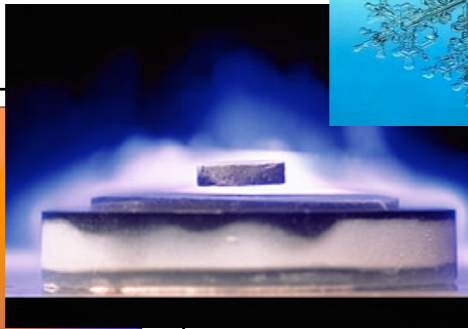
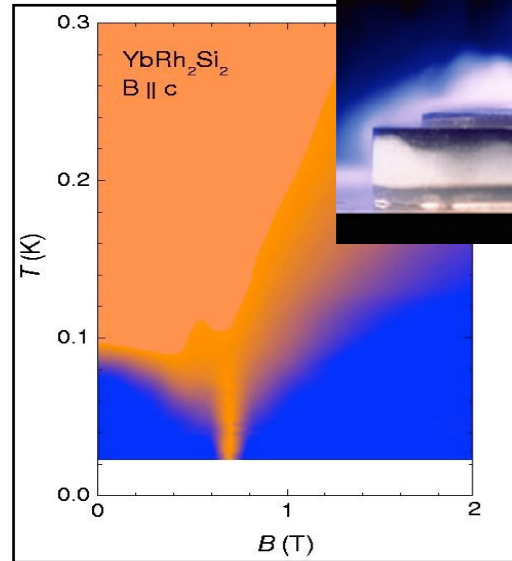

*“The behavior of large and complex aggregations of elementary particles, it turns out, is not to be understood in terms of a simple extrapolation of the properties of a few particles. Instead, at each level of complexity entirely new properties appear, and the understanding of the new behaviors requires research which I think is as fundamental in its nature as any other.” Philip. W. Anderson “More is Different”, 1967.*

# More is Different

Å | | | | μm

Quantum Phase

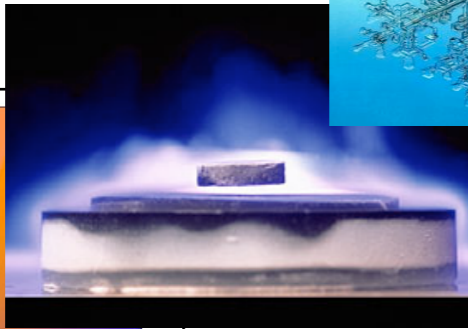
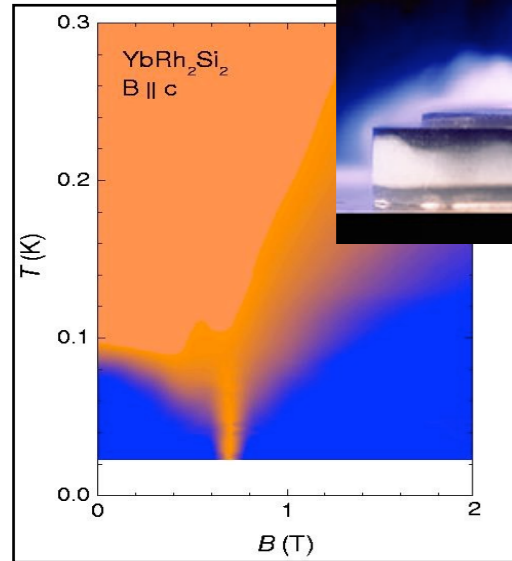

*“The behavior of large and complex aggregations of elementary particles, it turns out, is not to be understood in terms of a simple extrapolation of the properties of a few particles. Instead, at each level of complexity entirely new properties appear, and the understanding of the new behaviors requires research which I think is as fundamental in its nature as any other.” Philip. W. Anderson “More is Different”, 1967.*

**From the Angstrom to the Micron**

Atom



Quantum Phase

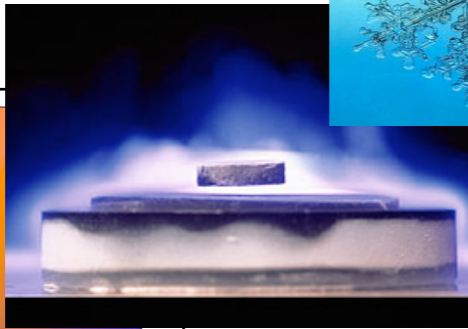
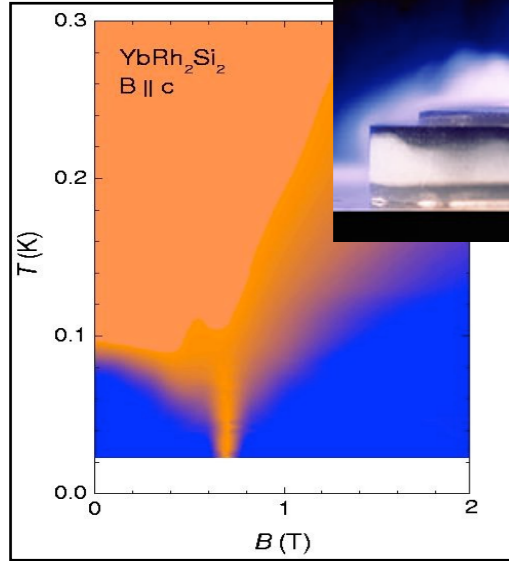

*“The behavior of large and complex aggregations of elementary particles, it turns out, is not to be understood in terms of a simple extrapolation of the properties of a few particles. Instead, at each level of complexity entirely new properties appear, and the understanding of the new behaviors requires research which I think is as fundamental in its nature as any other.” Philip. W. Anderson “More is Different”, 1967.*

**From the Angstrom to the Micron**

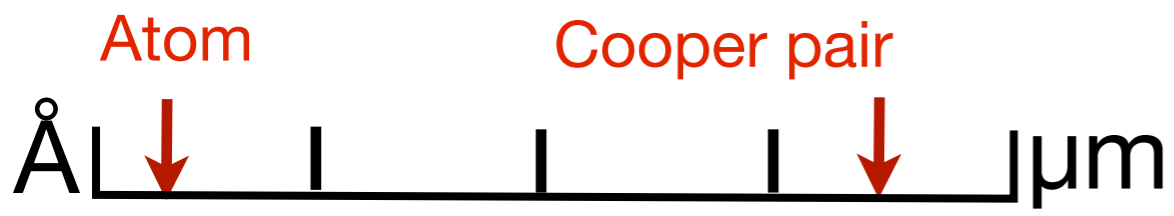

*“The behavior of large and complex aggregations of elementary particles, it turns out, is not to be understood in terms of a simple extrapolation of the properties of a few particles. Instead, at each level of complexity entirely new properties appear, and the understanding of the new behaviors requires research which I think is as fundamental in its nature as any other.” Philip. W. Anderson “More is Different”, 1967.*

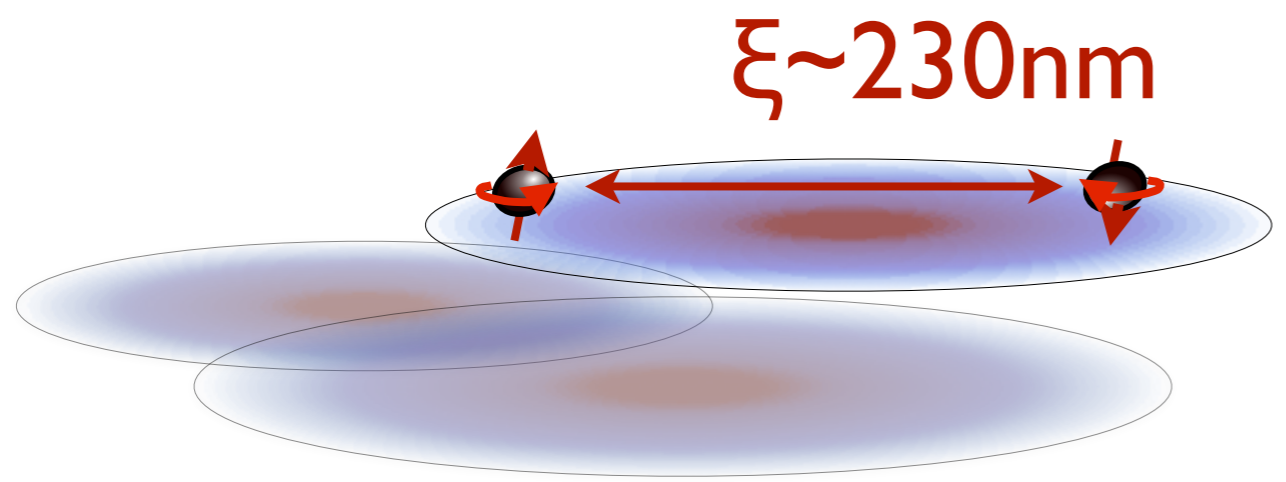
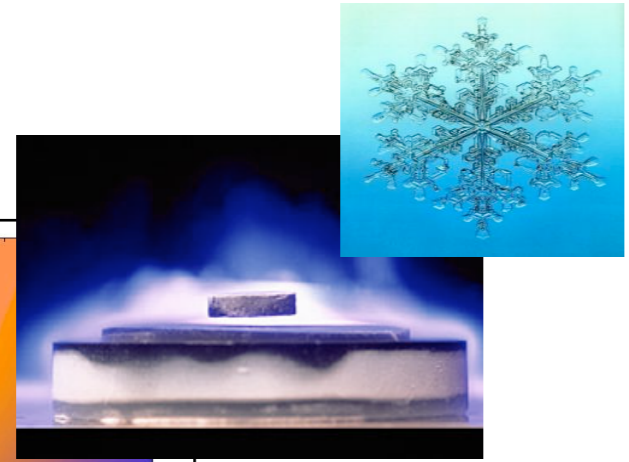
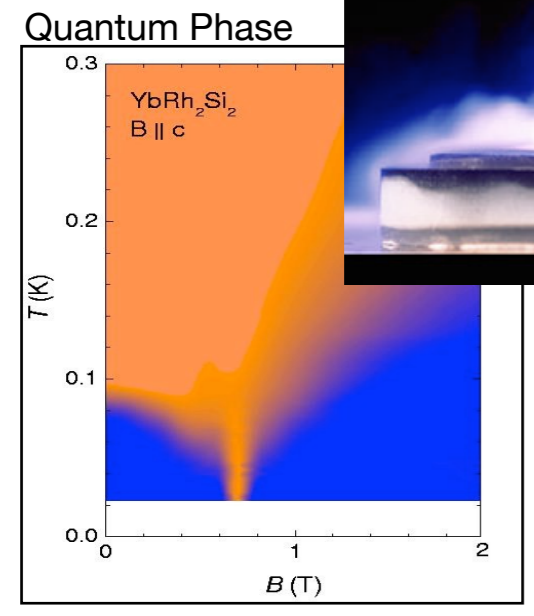

Cooper Pair in Sn

# From the Angstrom to the Micron

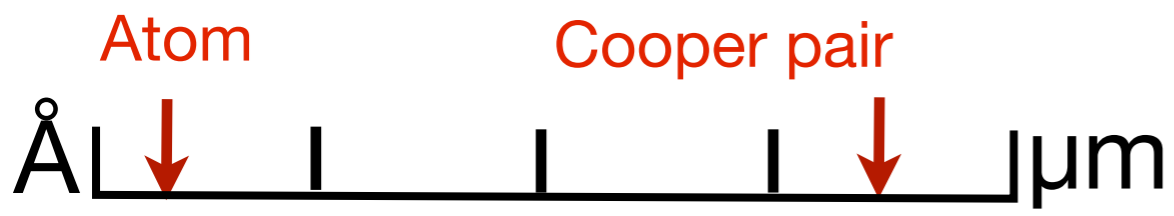

Quantum Phase

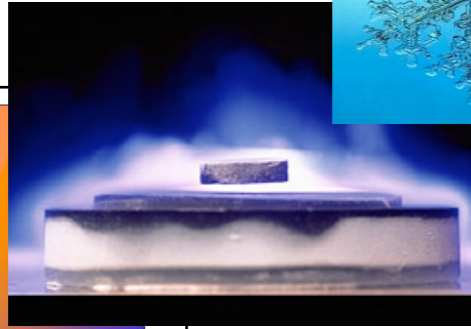
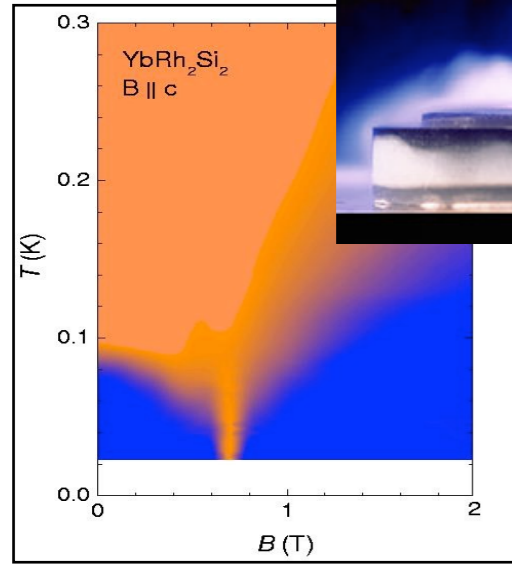

$\xi \sim 230\text{nm}$

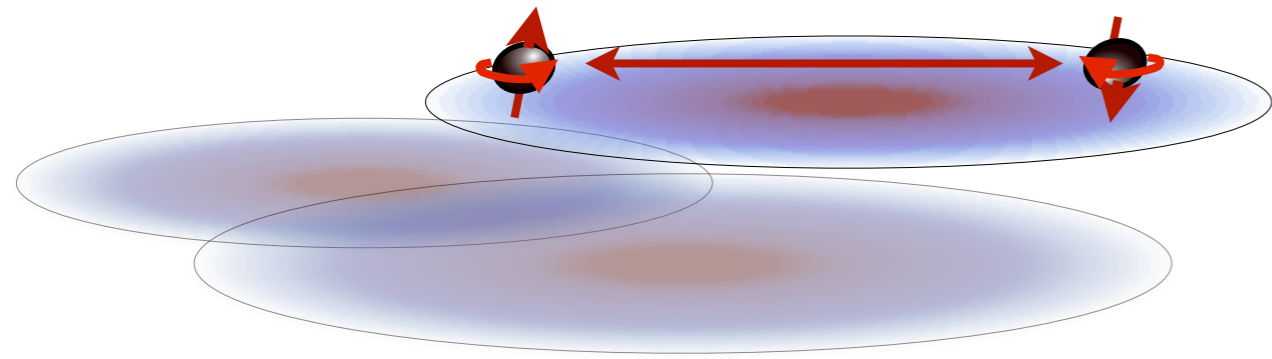

Cooper Pair in Sn

# From the Angstrom to the Micron



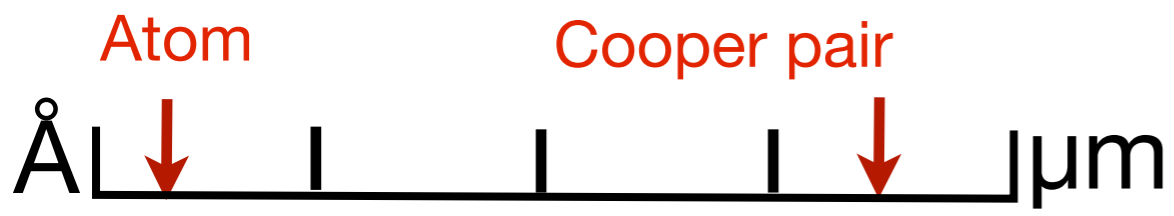

4f	Ce	Pr	Nd	Pm	Sm	Eu	Gd	Tb	Dy	Ho	Er	Tm	Yb
5f	Th	Pa	U	Np	Pu	Am	Cm	Bk	Cf	Es	Fm	Md	No
3d	Sc	Ti	V	Cr	Mn	Fe	Co	Ni	Cu				
4d	Y	Zr	Nb	Mo	Tc	Ru	Rh	Pd	Ag				
5d	Lu	Hf	Ta	W	Re	Os	Ir	Pt	Au				

### Universe of Quantum Materials

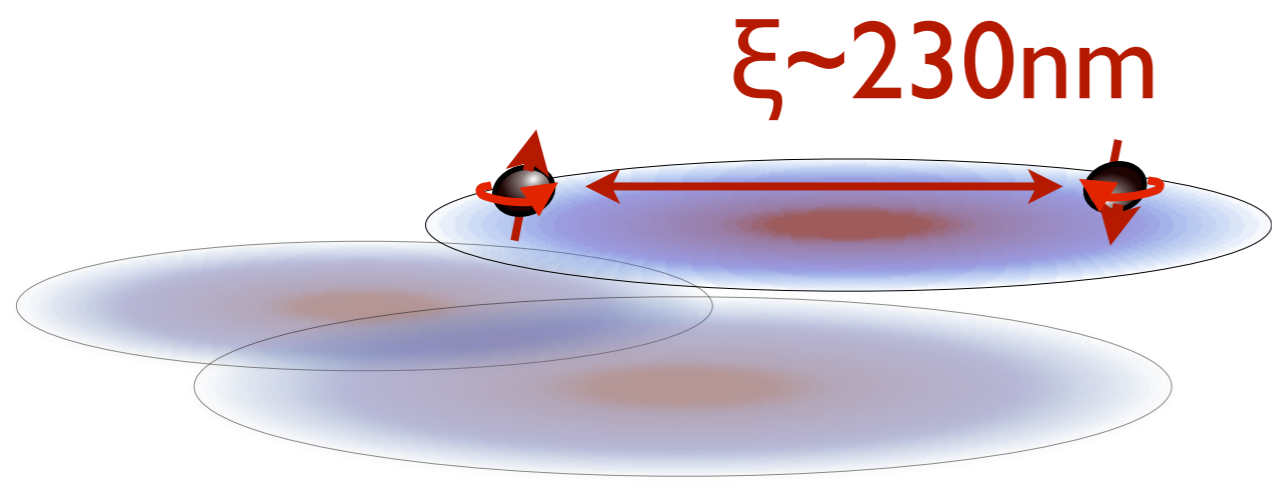
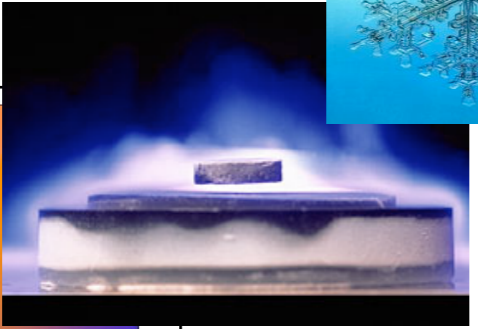
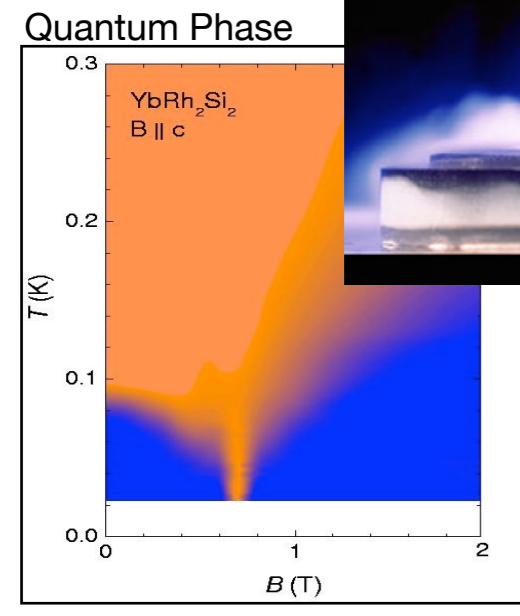

Cooper Pair in Sn

# From the Angstrom to the Micron

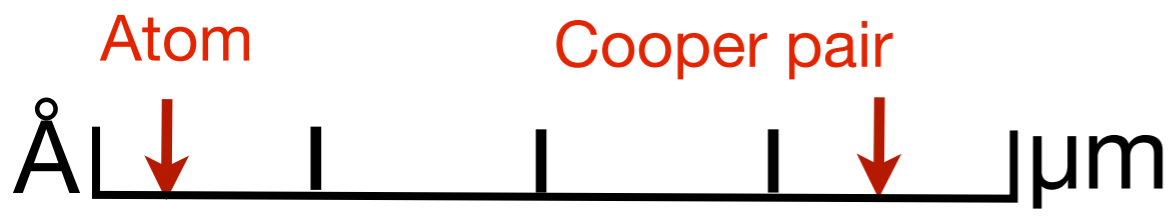

4f	Ce	Pr	Nd	Pm	Sm	Eu	Gd	Tb	Dy	Ho	Er	Tm	Yb
5f	Th	Pa	U	Np	Pu	Am	Cm	Bk	Cf	Es	Fm	Md	No
3d	Sc	Ti	V	Cr	Mn	Fe	Co	Ni	Cu				
4d	Y	Zr	Nb	Mo	Tc	Ru	Rh	Pd	Ag				
5d	Lu	Hf	Ta	W	Re	Os	Ir	Pt	Au				

**Universe of Quantum Materials**

$$|\Psi_A + \Psi_B|^2 \neq |\Psi_A|^2 + |\Psi_B|^2$$

Compounds are different to the sum of their components

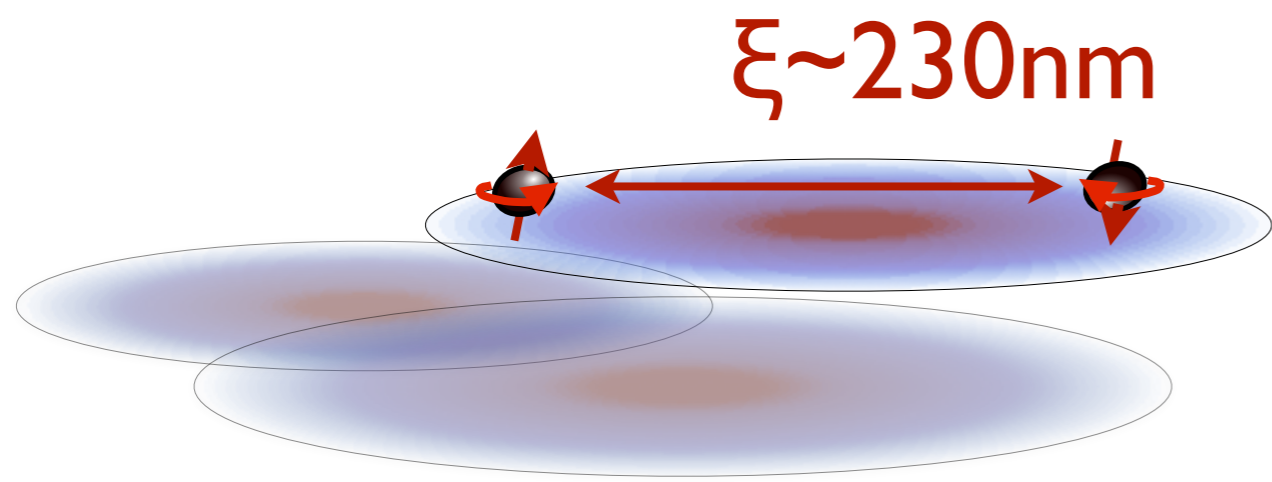
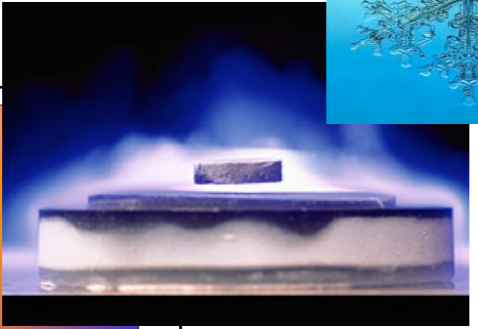
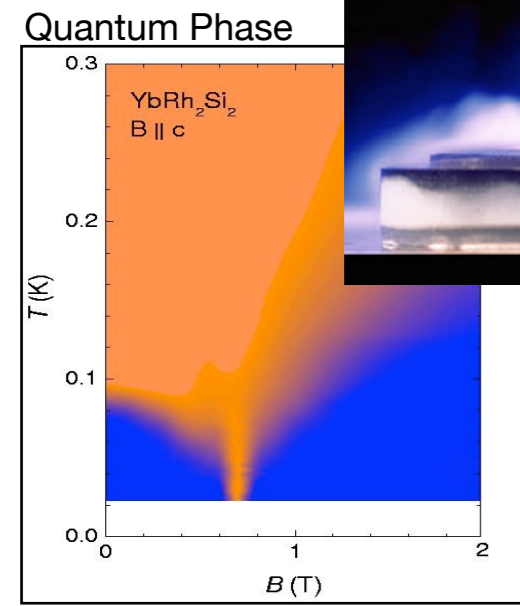

Cooper Pair in Sn

**From the Angstrom to the Micron**

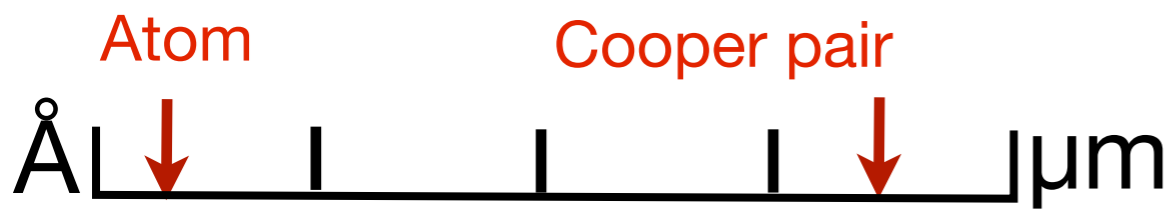

4f	Ce	Pr	Nd	Pm	Sm	Eu	Gd	Tb	Dy	Ho	Er	Tm	Yb
5f	Th	Pa	U	Np	Pu	Am	Cm	Bk	Cf	Es	Fm	Md	No
3d	Sc	Ti	V	Cr	Mn	Fe	Co	Ni	Cu				
4d	Y	Zr	Nb	Mo	Tc	Ru	Rh	Pd	Ag				
5d	Lu	Hf	Ta	W	Re	Os	Ir	Pt	Au				

**Universe of Quantum Materials**

$$|\Psi_A + \Psi_B|^2 \neq |\Psi_A|^2 + |\Psi_B|^2$$

Compounds are different to the sum of their components

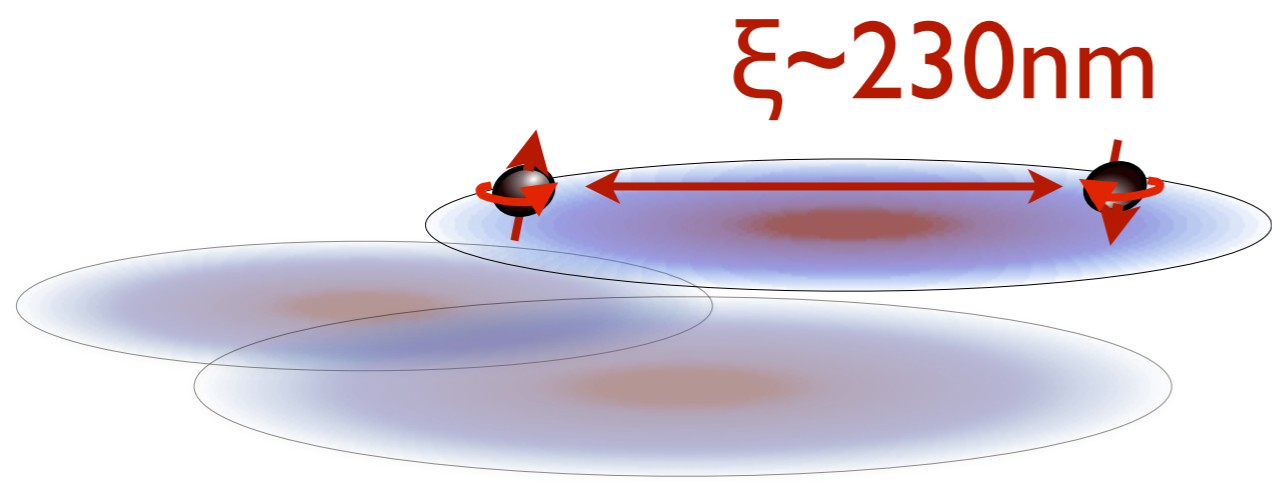
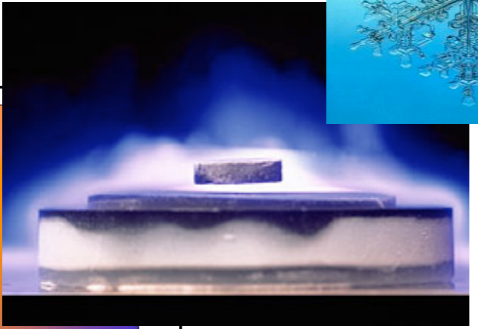
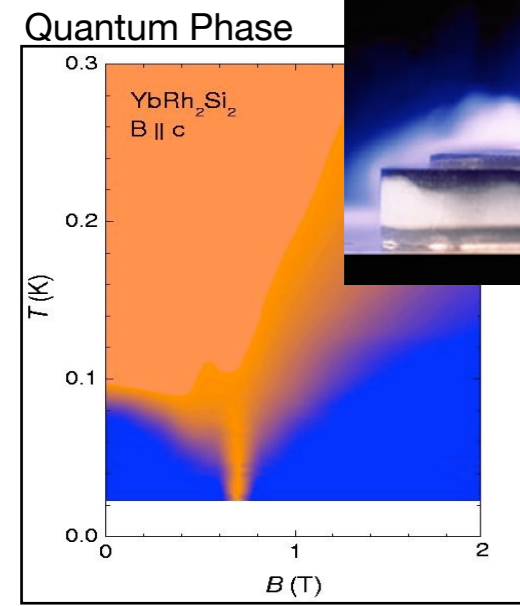

Cooper Pair in Sn

**From the Angstrom to the Micron**

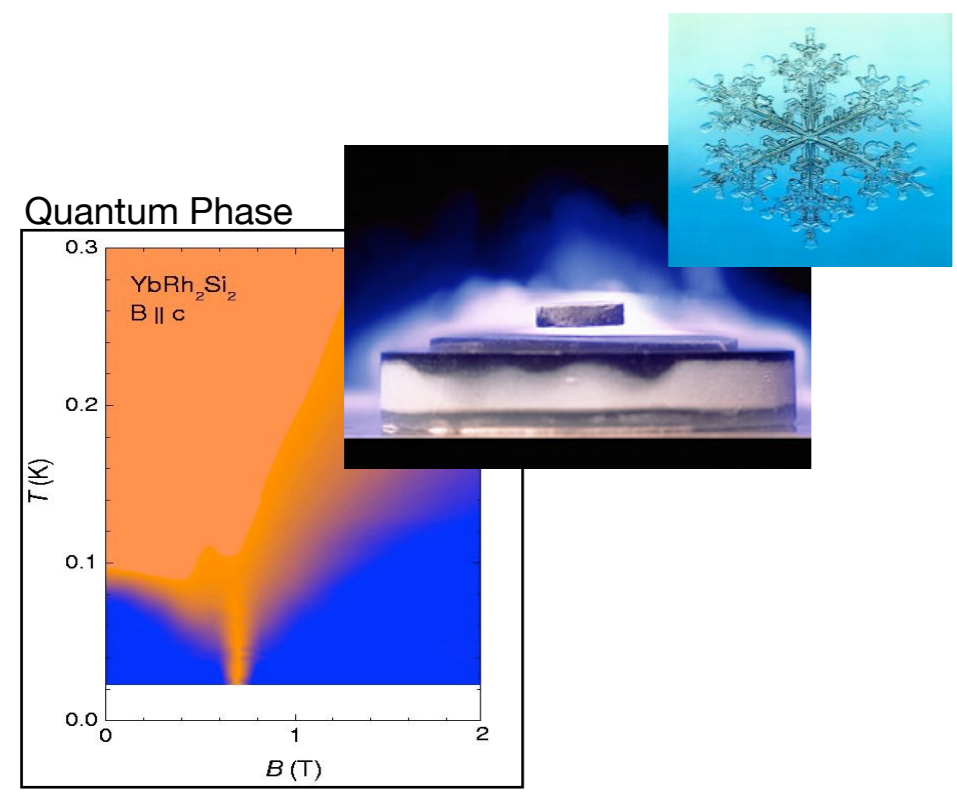
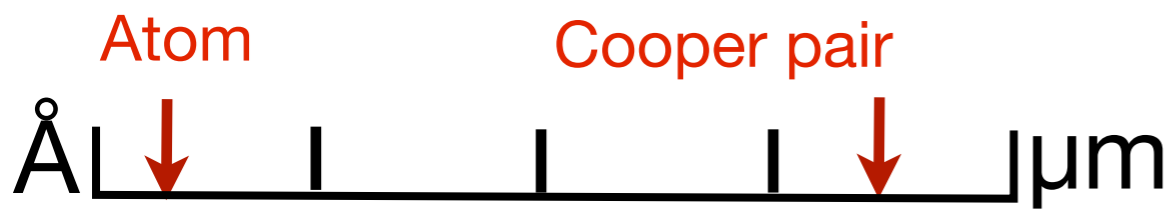

4f	Ce	Pr	Nd	Pm	Sm	Eu	Gd	Tb	Dy	Ho	Er	Tm	Yb
5f	Th	Pa	U	Np	Pu	Am	Cm	Bk	Cf	Es	Fm	Md	No
3d	Sc	Ti	V	Cr	Mn	Fe	Co	Ni	Cu				
4d	Y	Zr	Nb	Mo	Tc	Ru	Rh	Pd	Ag				
5d	Lu	Hf	Ta	W	Re	Os	Ir	Pt	Au				

**Universe of Quantum Materials**

$$|\Psi_A + \Psi_B|^2 \neq |\Psi_A|^2 + |\Psi_B|^2$$

Compounds are different to the sum of their components

Each compound is a miniature quantum universe, with its own types of emergent properties.

The “Quantum Phase transitions” which separate the worlds can be likened to black holes in the fabric of the phase diagram.

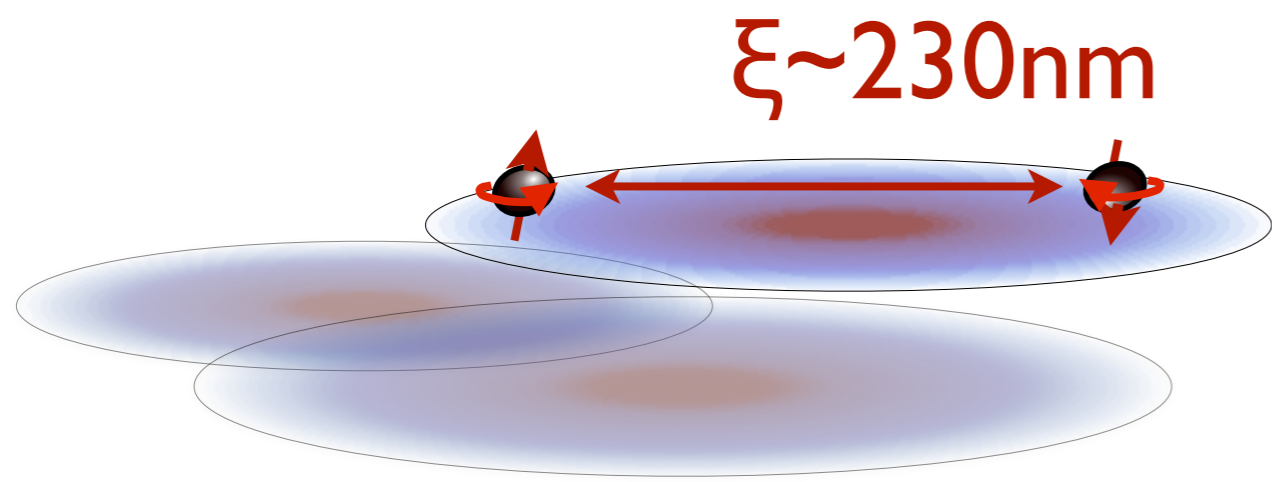

Cooper Pair in Sn

**From the Angstrom to the Micron**

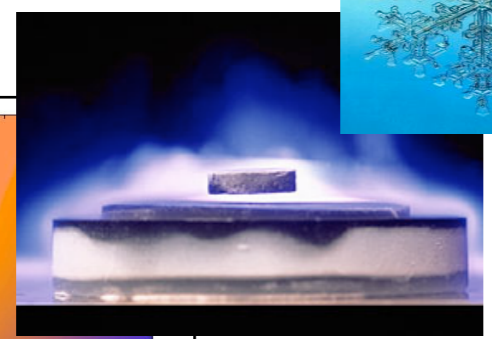
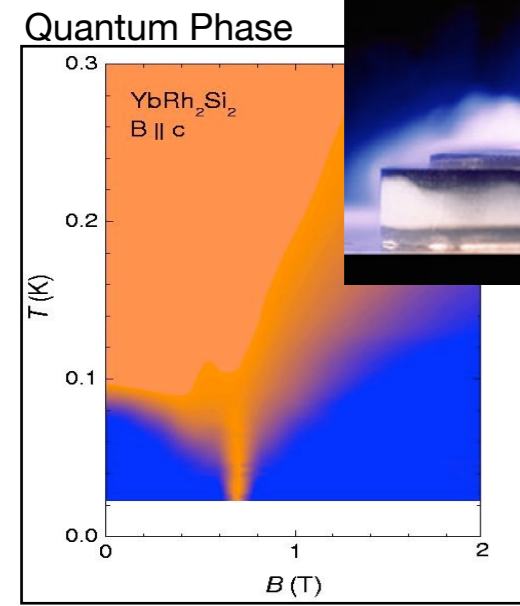
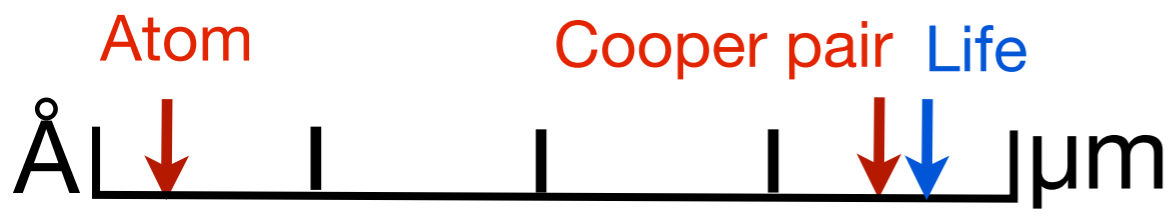

*Mycoplasma mycoides*

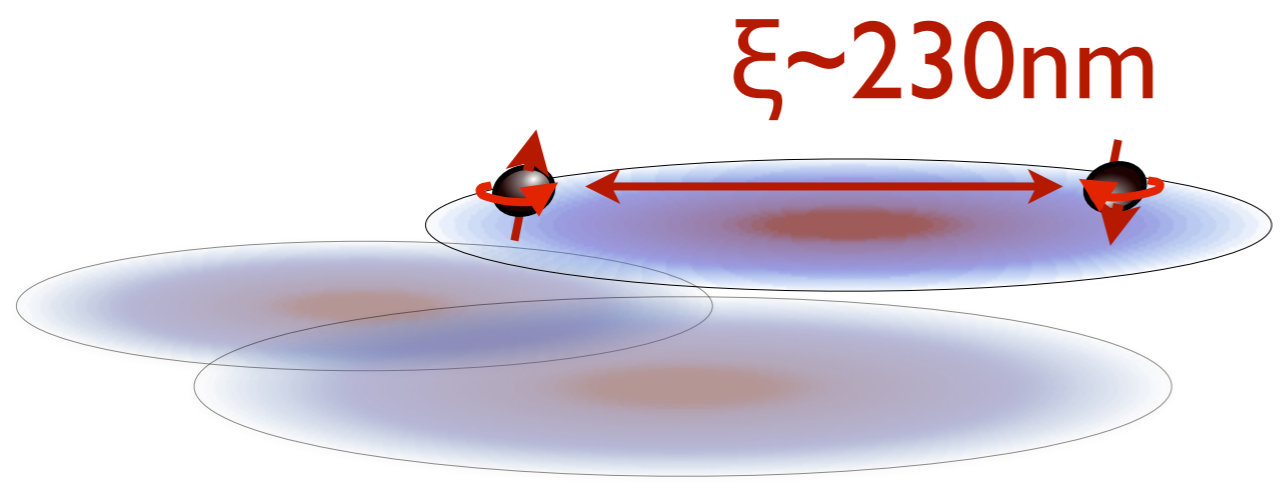
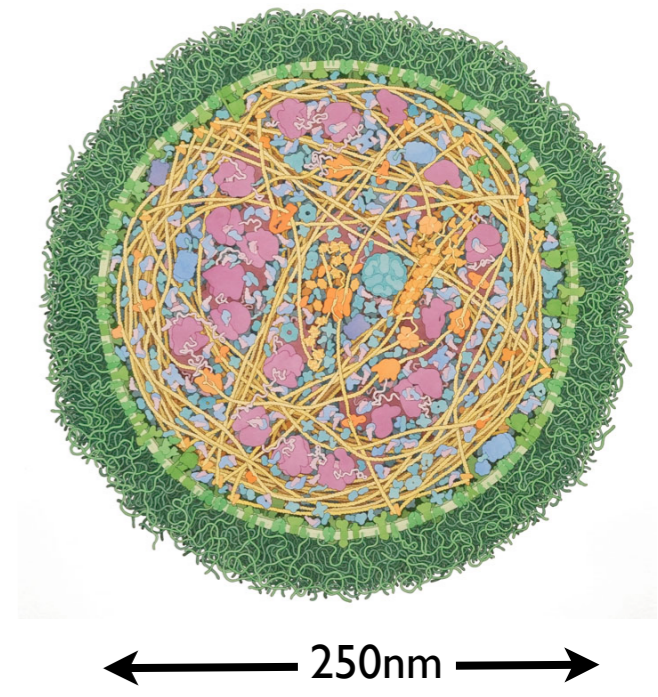

Cooper Pair in Sn

# From the Angstrom to the Micron

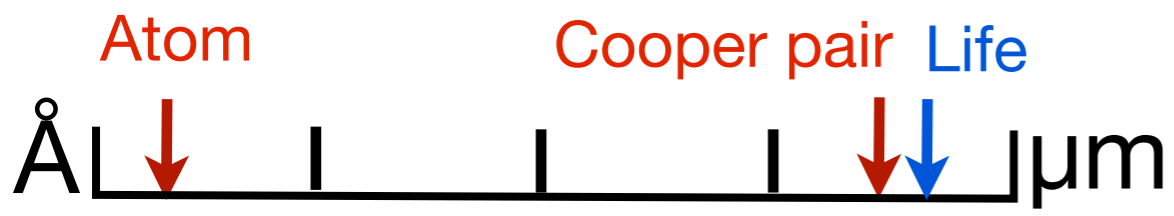

*Mycoplasma mycoides*

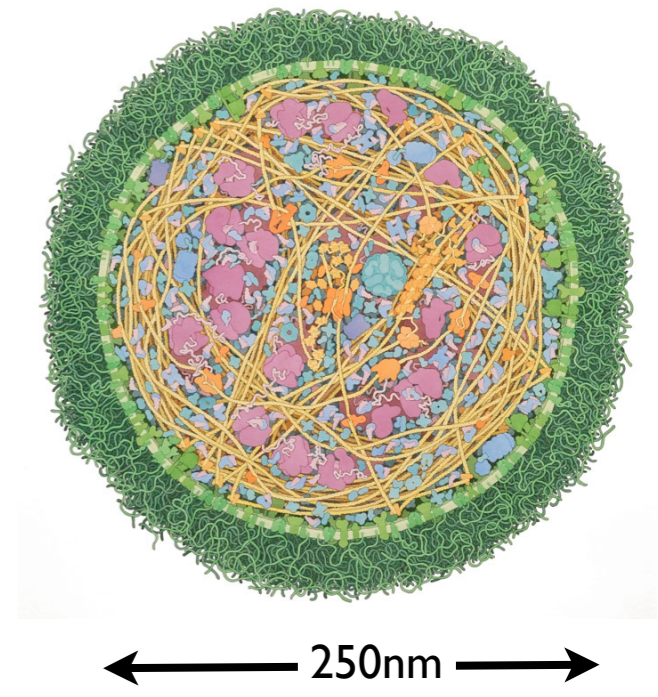

“Emergence”

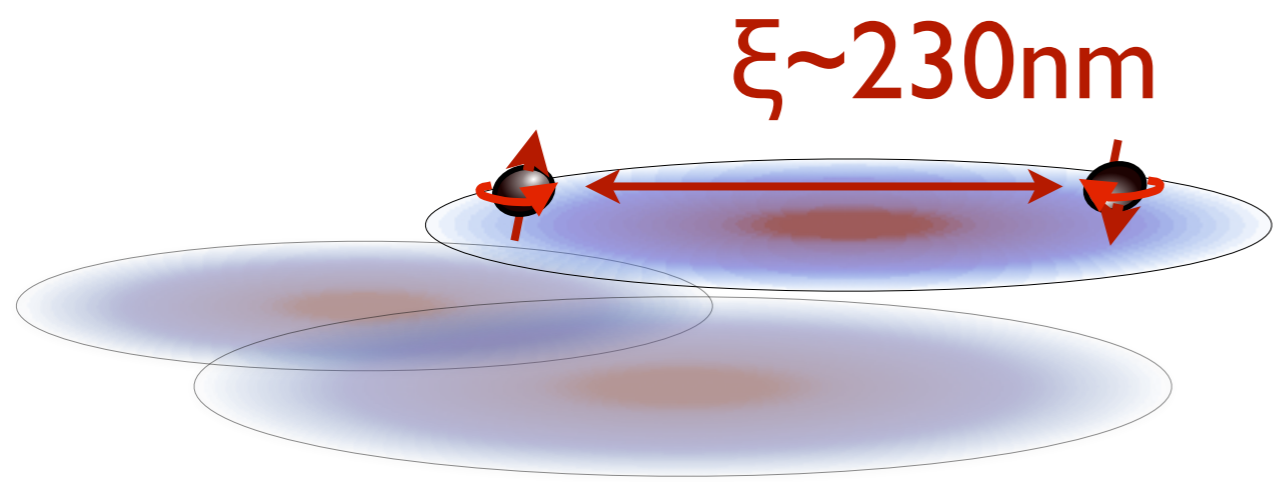
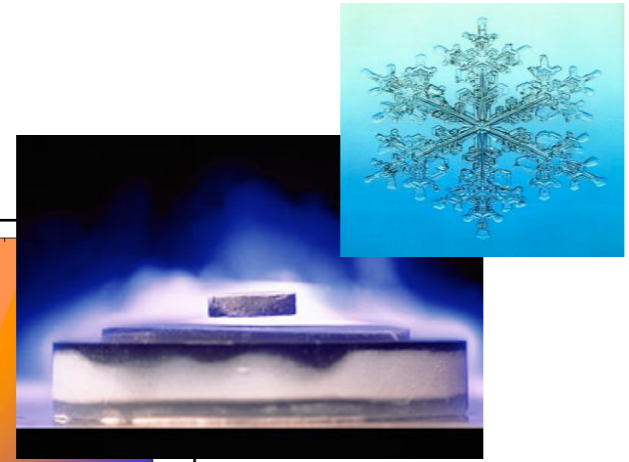
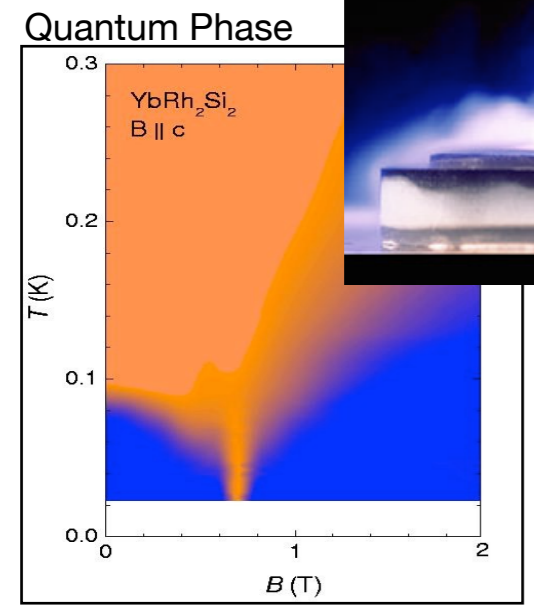

Cooper Pair in Sn

From the Angstrom to the Micron

# Quantum Materials in the age of QI

# Quantum Materials in the age of QI



Birds

At the turn of the 20th century Otto Lilienthal and the Wright Brothers looked to birds for the principles of aerodynamics and Flight

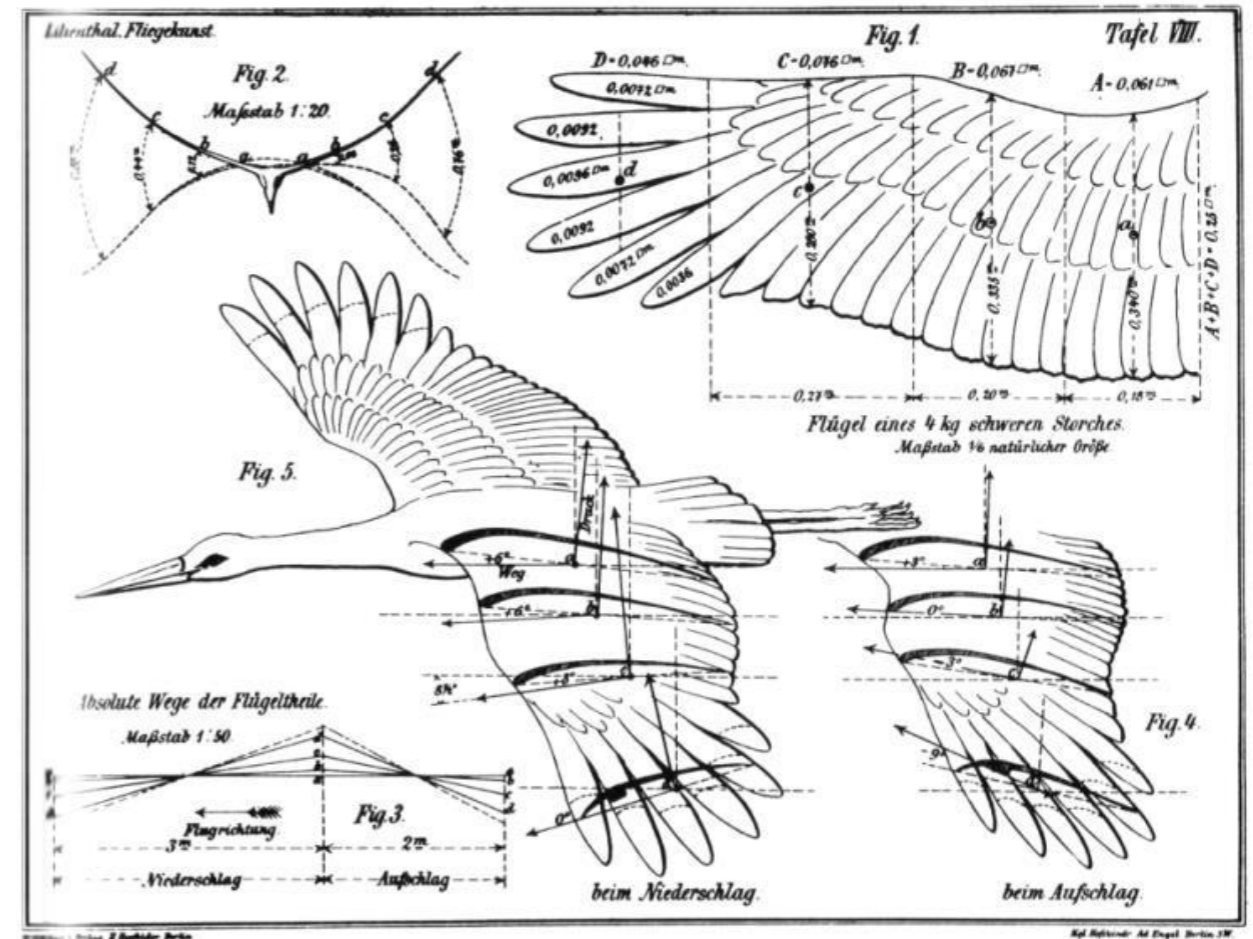

Otto Lilienthal, Der Vogelflug als Grundlage der Fliegekunst, 1899



# Quantum Materials in the age of QI

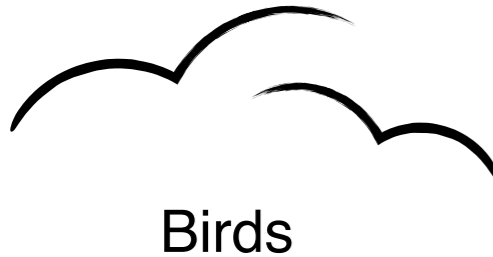

Birds

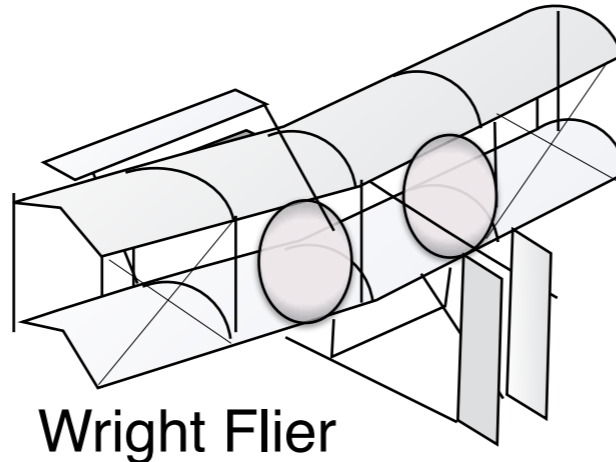

Wright Flier

At the turn of the 20th century Otto Lilienthal and the Wright Brothers looked to birds for the principles of aerodynamics and Flight

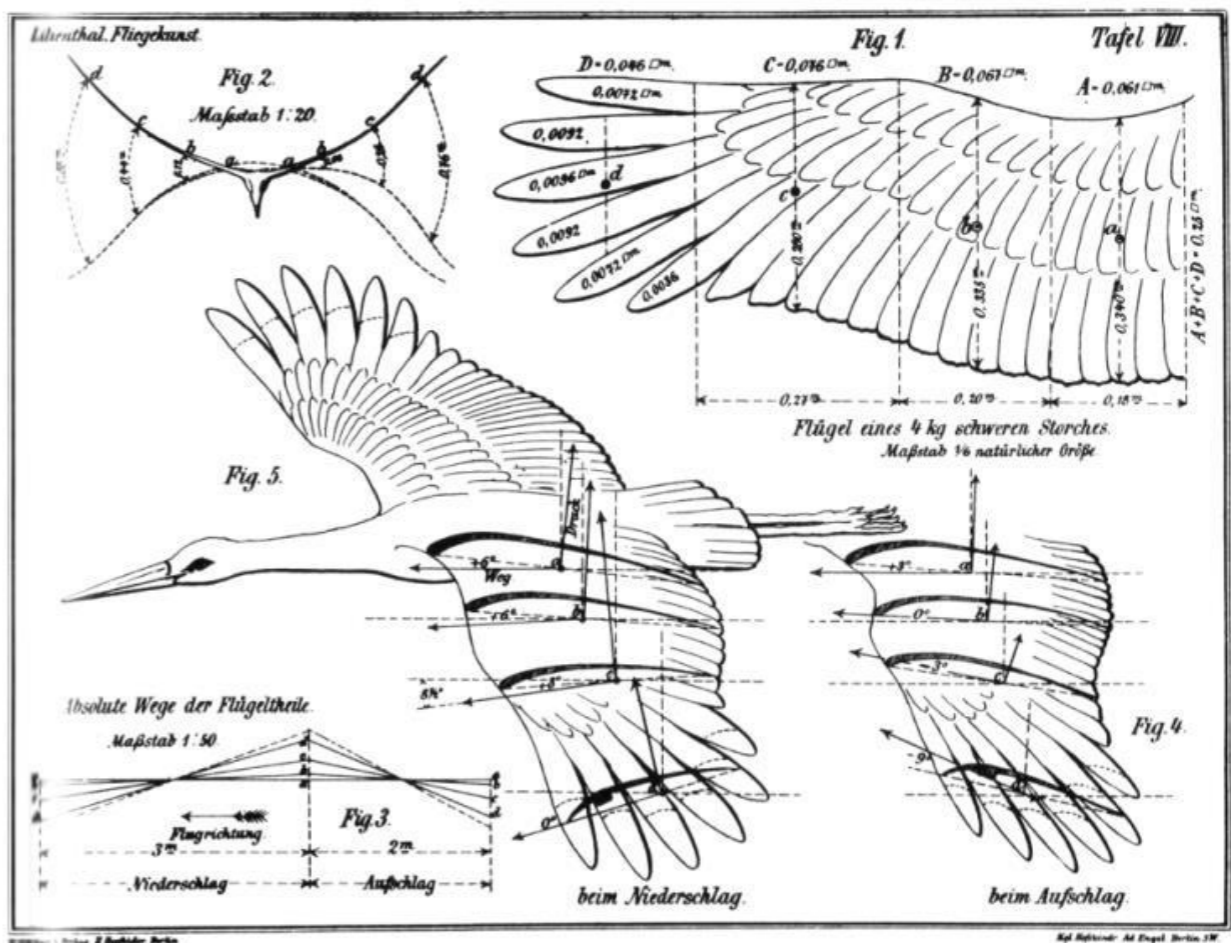

Otto Lilienthal, Der Vogelflug als Grundlage der Fliegekunst, 1899

# Quantum Materials in the age of QI



Birds

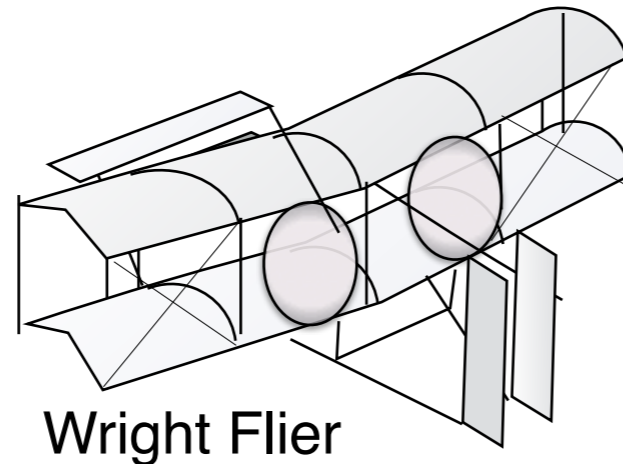

Wright Flier

At the turn of the 21st century, Quantum Materials provide equally important insights into how we may understand and control the quantum physics of entanglement

At the turn of the 20th century Otto Lilienthal and the Wright Brothers looked to birds for the principles of aerodynamics and Flight

# Quantum Materials in the age of QI



Birds

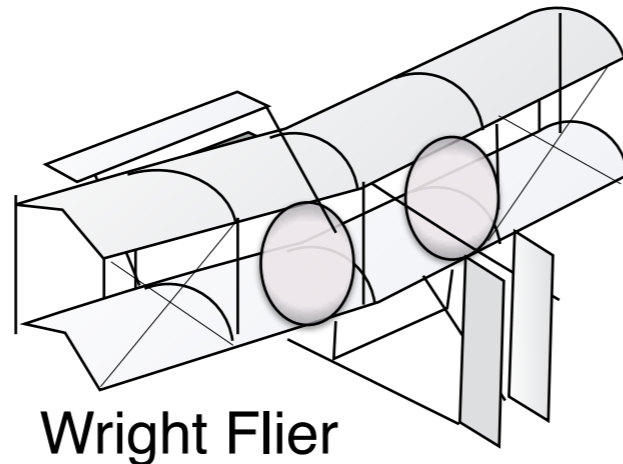

Wright Flier

At the turn of the 20th century Otto Lilienthal and the Wright Brothers looked to birds for the principles of aerodynamics and Flight

At the turn of the 21st century, Quantum Materials provide equally important insights into how we may understand and control the quantum physics of entanglement

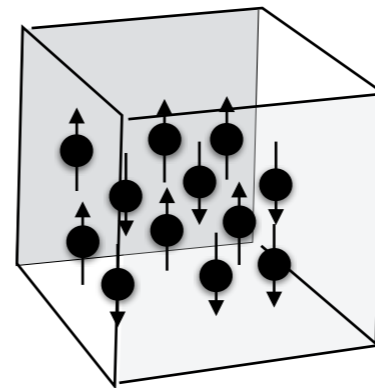

# Quantum Materials in the age of QI



Birds

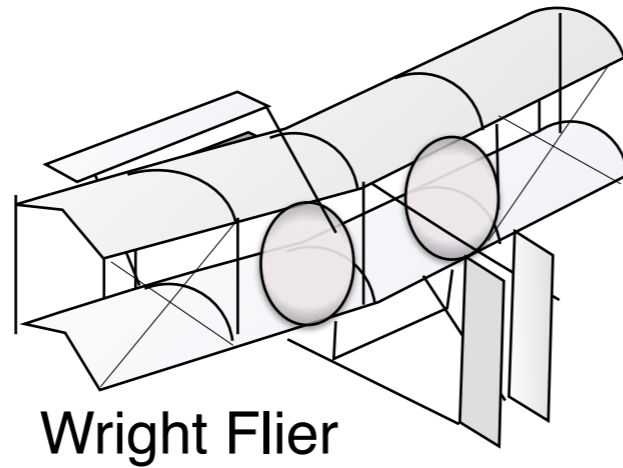

Wright Flier

At the turn of the 20th century Otto Lilienthal and the Wright Brothers looked to birds for the principles of aerodynamics and Flight

At the turn of the 21st century, Quantum Materials provide equally important insights into how we may understand and control the quantum physics of entanglement

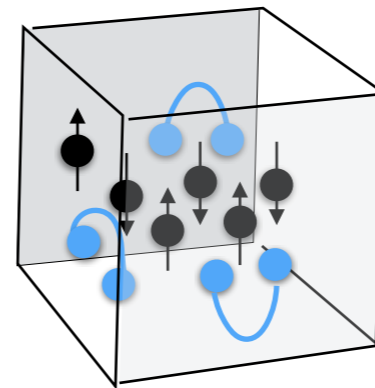

Quantum Materials

$10^{23}$  qubits

$$\prod_{(i,j)} (|\uparrow\rangle_i |\downarrow\rangle_j - |\downarrow\rangle_i |\uparrow\rangle_j)$$

Entanglement

# Quantum Materials in the age of QI

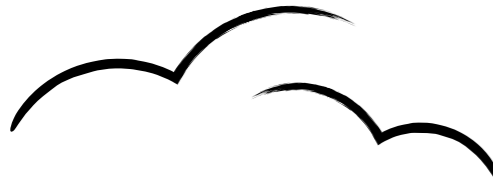

Birds

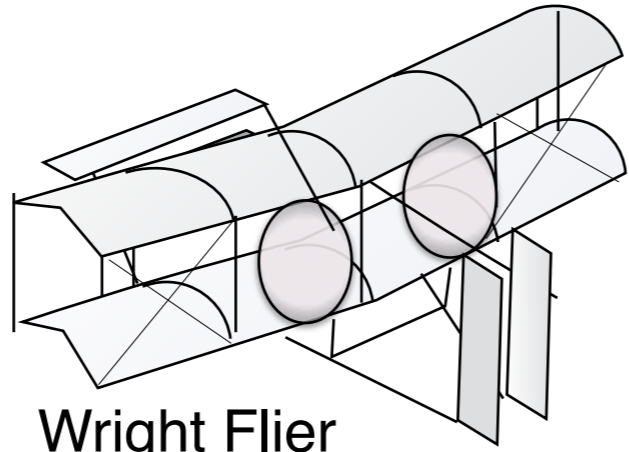

Wright Flier

At the turn of the 20th century Otto Lilienthal and the Wright Brothers looked to birds for the principles of aerodynamics and Flight

At the turn of the 21st century, Quantum Materials provide equally important insights into how we may understand and control the quantum physics of entanglement

Novel phases of matter  
Hi Tc, Topological, FQHE

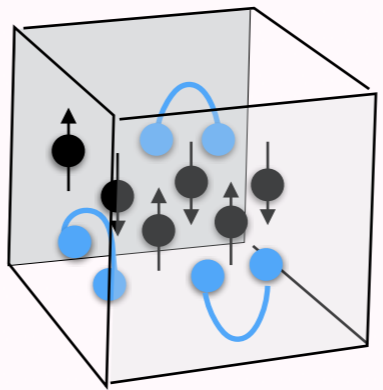

Quantum Materials

**10<sup>23</sup> qubits**

$$\prod_{(i,j)} (|\uparrow\rangle_i |\downarrow\rangle_j - |\downarrow\rangle_i |\uparrow\rangle_j)$$

Entanglement

# Quantum Materials in the age of QI



Birds

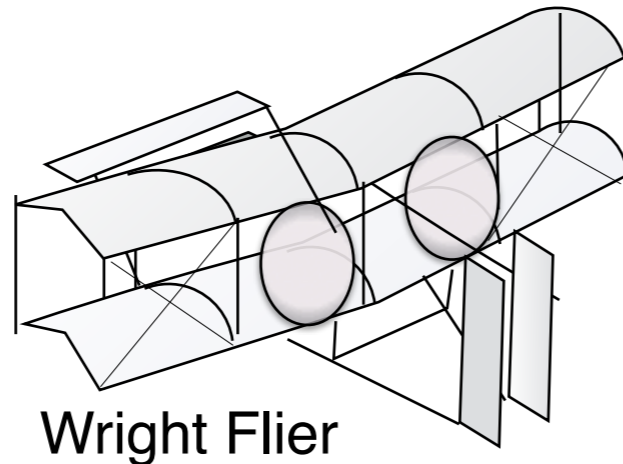

Wright Flier

At the turn of the 20th century Otto Lilienthal and the Wright Brothers looked to birds for the principles of aerodynamics and Flight

At the turn of the 21st century, Quantum Materials provide equally important insights into how we may understand and control the quantum physics of entanglement

Novel phases of matter  
Hi Tc, Topological, FQHE

**Quantum computers**  
 $a|0110\rangle + b|1010\rangle + \dots$

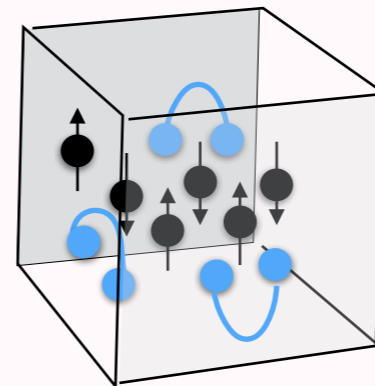

Quantum Materials

$$\prod_{(i,j)} (|\uparrow\rangle_i |\downarrow\rangle_j - |\downarrow\rangle_i |\uparrow\rangle_j)$$

Entanglement

$10^{23}$  qubits

# Quantum Materials in the age of QI



Birds

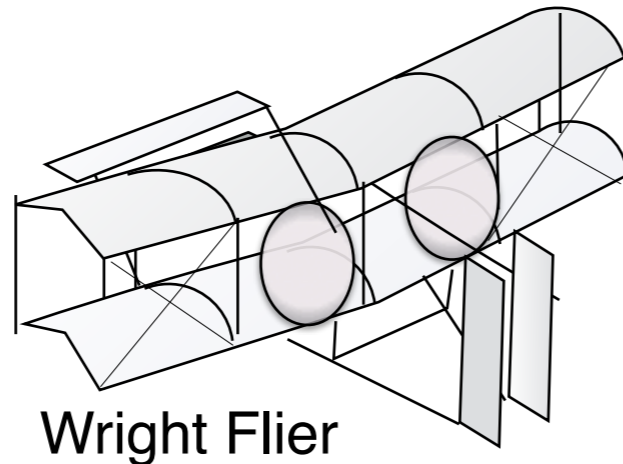

Wright Flier

At the turn of the 20th century Otto Lilienthal and the Wright Brothers looked to birds for the principles of aerodynamics and Flight

At the turn of the 21st century, Quantum Materials provide equally important insights into how we may understand and control the quantum physics of entanglement

## Designer Quantum Materials

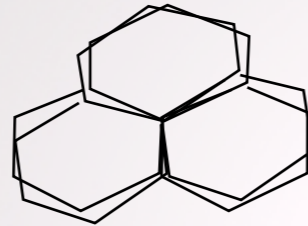

Novel phases of matter  
Hi Tc, Topological, FQHE

## Quantum computers

$$a|0110\rangle + b|1010\rangle + \dots$$

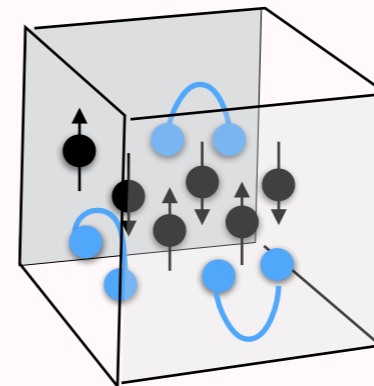

$10^{23}$  qubits

## Quantum Materials

$$\prod_{(i,j)} (|\uparrow\rangle_i |\downarrow\rangle_j - |\downarrow\rangle_i |\uparrow\rangle_j)$$

Entanglement

# Quantum Materials in the age of QI

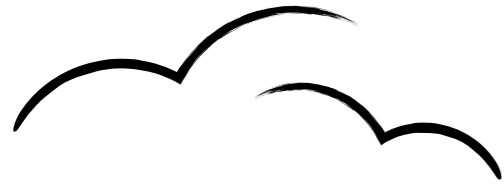

Birds

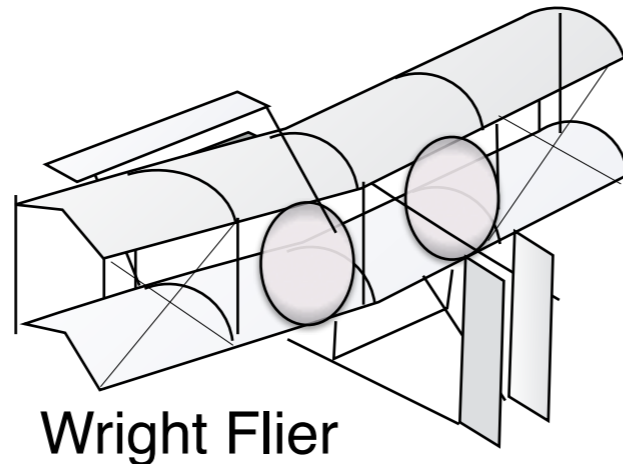

Wright Flier

At the turn of the 20th century Otto Lilienthal and the Wright Brothers looked to birds for the principles of aerodynamics and Flight

At the turn of the 21st century, Quantum Materials provide equally important insights into how we may understand and control the quantum physics of entanglement

## Designer Quantum Materials

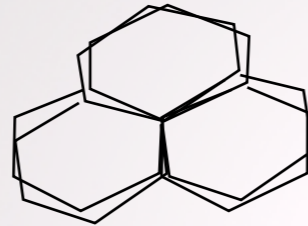

Novel phases of matter  
Hi Tc, Topological, FQHE

## Quantum computers

$$a|0110\rangle + b|1010\rangle + \dots$$

Quantum Phase transitions:  
Infinite range entanglement

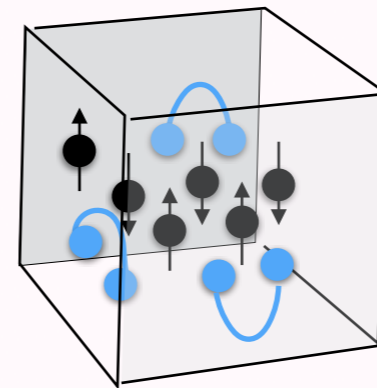

**10<sup>23</sup>** qubits

## Quantum Materials

$$\prod_{(i,j)} (|\uparrow\rangle_i |\downarrow\rangle_j - |\downarrow\rangle_i |\uparrow\rangle_j)$$

Entanglement



# Quantum Materials in the age of QI



Birds

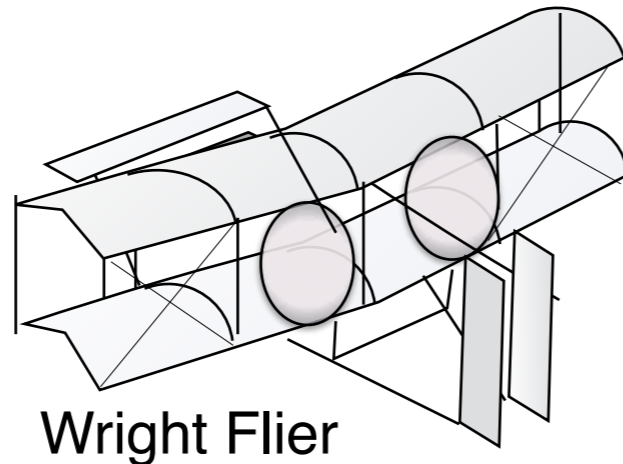

Wright Flier

At the turn of the 20th century Otto Lilienthal and the Wright Brothers looked to birds for the principles of aerodynamics and Flight

At the turn of the 21st century, Quantum Materials provide equally important insights into how we may understand and control the quantum physics of entanglement

## Designer Quantum Materials

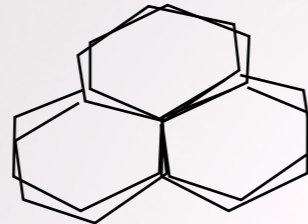

## Quantum computers

$$a|0110\rangle + b|1010\rangle + \dots$$

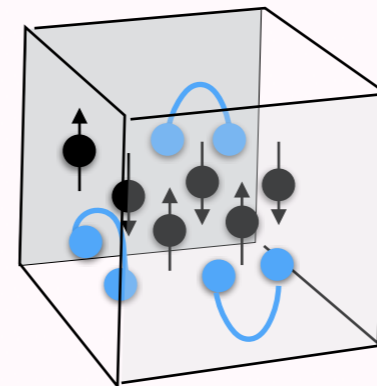

Quantum Phase transitions:  
Infinite range entanglement

Novel phases of matter  
Hi Tc, Topological, FQHE

$10^{23}$  qubits

## Quantum Materials

$$\prod_{(i,j)} (|\uparrow\rangle_i |\downarrow\rangle_j - |\downarrow\rangle_i |\uparrow\rangle_j)$$

Entanglement

What patterns of entanglement can be realized in Nature?

# Quantum Materials in the age of QI



Birds

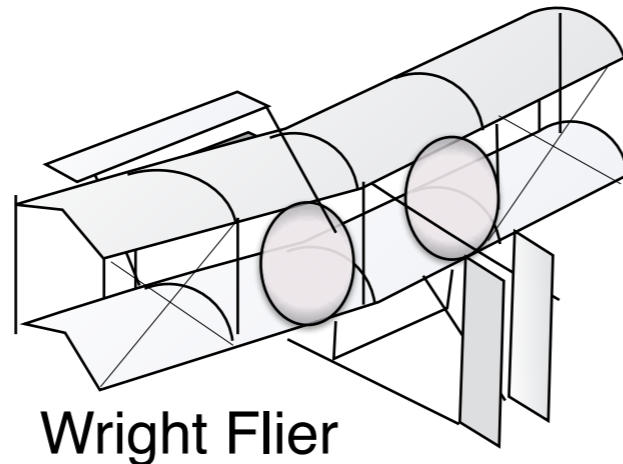

Wright Flier

At the turn of the 20th century Otto Lilienthal and the Wright Brothers looked to birds for the principles of aerodynamics and Flight

At the turn of the 21st century, Quantum Materials provide equally important insights into how we may understand and control the quantum physics of entanglement

## Designer Quantum Materials

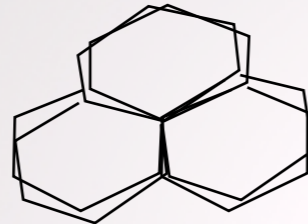

## Quantum computers

$$a|0110\rangle + b|1010\rangle + \dots$$

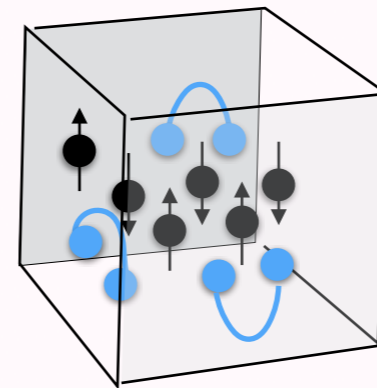

Quantum Phase transitions:  
Infinite range entanglement

Novel phases of matter  
Hi Tc, Topological, FQHE

$10^{23}$  qubits

## Quantum Materials

$$\prod_{(i,j)} (|\uparrow\rangle_i |\downarrow\rangle_j - |\downarrow\rangle_i |\uparrow\rangle_j)$$

Entanglement

What patterns of entanglement can be realized in Nature?

What conceptual framework will unify QI and QFT?

# Quantum Materials in the age of QI



Birds

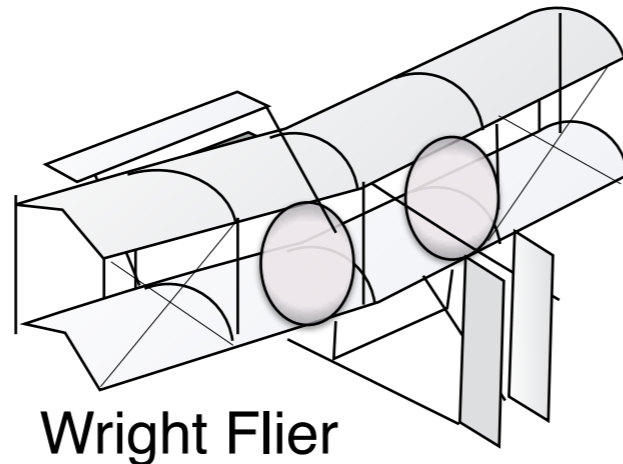

Wright Flier

At the turn of the 20th century Otto Lilienthal and the Wright Brothers looked to birds for the principles of aerodynamics and Flight

At the turn of the 21st century, Quantum Materials provide equally important insights into how we may understand and control the quantum physics of entanglement

## Designer Quantum Materials

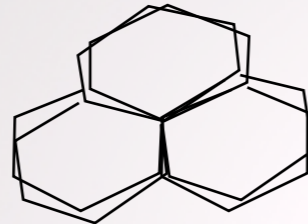

## Quantum computers

$$a|0110\rangle + b|1010\rangle + \dots$$

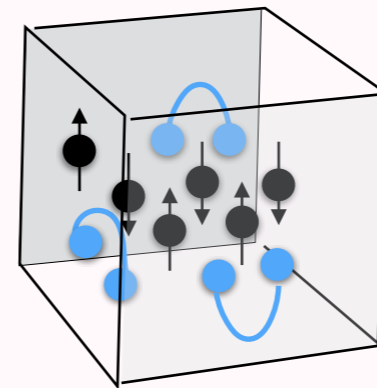

Quantum Phase transitions:  
Infinite range entanglement

Novel phases of matter  
Hi Tc, Topological, FQHE

$10^{23}$  qubits

Possible Generalizations to the cosmos  
eg Anderson Higgs Mechanism  
Superfluidity in pulsars

## Quantum Materials

$$\prod_{(i,j)} (|\uparrow\rangle_i |\downarrow\rangle_j - |\downarrow\rangle_i |\uparrow\rangle_j)$$

Entanglement

What patterns of entanglement can be realized in Nature?

What conceptual framework will unify QI and QFT?